

# CORESTA RECOMMENDED METHOD N° 22

## ROUTINE ANALYTICAL CIGARETTE-SMOKING MACHINE SPECIFICATIONS, DEFINITIONS AND STANDARD CONDITIONS

(August 1991)

### 0. INTRODUCTION

This CORESTA Recommended Method includes the requirements found necessary in the light of knowledge and experience gained with analytical cigarette-smoking machines.

Other aspects relevant to the recommended method on mechanical smoking include methods of test for smoking machines, cigarette sampling and expression of results.

### 1. FIELD OF APPLICATION

This Recommended Method :

- defines the smoking parameters and specifies the standard conditions to be provided for the routine analytical machine smoking of cigarettes;
- specifies requirements for a routine analytical smoking machine complying with the standard conditions.

*Note* : Annex A describes, by way of example, the special characteristics of a typical smoking machine incorporating a piston type of puffing mechanism.

Annex B includes a diagram of a puff profile and illustrates certain definitions and standard conditions.

### 2. DEFINITIONS

#### 2.1. *Ambient Conditions*

The whole of the variable parameters physically characterising the conditions in the room and environment in which the analytical smoking is carried out.

#### 2.2. *Butt Length*

The length of unburnt cigarette remaining at the moment when the smoking is stopped.

#### 2.3. *Restricted Smoking*

The condition that exists when the butt end of a cigarette is closed to the atmosphere between successive puffs.

#### 2.4. *Free Smoking*

The condition that exists when the butt end of a cigarette is completely exposed to the atmosphere between successive puffs.

**2.5. *Pressure Drop***

The difference in static pressure between any two points of the pneumatic circuit of a smoking machine which are passed by a current of air at a constant flow rate of  $17.5 \text{ cm}^3 \text{ sec}^{-1}$ .

*Note :* The term draw resistance has a very similar meaning. To avoid any confusion the term draw resistance is used for cigarettes and filter rods, whereas the term pressure drop is used by analogy in the case of the pneumatic circulation in a smoking machine.

**2.6. *Puff Duration***

The interval of time during which the port is connected with the suction mechanism.

**2.7. *Puff Volume***

The volume leaving the butt end of a cigarette and passing through the smoke trap.

**2.8. *Puff Number***

The number of puffs necessary to smoke a cigarette to a specified butt length.

**2.9. *Puff Frequency***

The number of puffs in a given time.

**2.10. *Puff Termination***

The ending of the connection of the port with the suction mechanism.

**2.11. *Puff Profile***

The flow rate measured directly behind the butt end of a cigarette and depicted graphically as a function of time.

**2.12. *Dead Volume***

The volume which exists between the butt end of a cigarette and the suction mechanism.

**2.13. *Cigarette Holder***

The device for holding the mouth end of a cigarette during smoking.

**2.14. *Smoke Trap***

The device for collecting such part of the smoke from a sample of cigarettes as is necessary for the determination of specified smoke components.

**2.15. *Port***

The aperture of the suction mechanism through which a puff is drawn and to which is attached a smoke trap.

**2.16. *Channel***

An element of a smoking machine consisting of one or more cigarette holders, one trap and a means of drawing a puff through the trap.

**2.17. Compensation**

The ability to maintain constant puff volumes and puff profiles when the pressure drop at the port changes.

**2.18. Cigarette Position**

The position of a cigarette on the smoking machine. In particular it is determined by the angle made by the longitudinal axis of the cigarette and the horizontal plane when a cigarette is inserted into a cigarette holder in an analytical smoking machine.

**2.19. Mainstream Smoke**

All smoke which leaves the butt end of a cigarette during the smoking process.

**2.20. Sidestream Smoke**

All smoke which leaves a cigarette during the smoking process other than from the butt end.

**2.21. Ashtray**

The device positioned under the cigarettes in their holders to collect ash falling from the cigarettes during smoking.

**2.22. Clearing Puff**

Any puff taken after the cigarette has been extinguished or removed from the cigarette holder.

### **3. REFERENCES**

*CORESTA Recommended Method N° 21: 1991*

Atmosphere for conditioning and testing tobacco and tobacco products.

*CORESTA Recommended Method N° 25: 1991*

Ambient air flow around cigarettes in routine analytical smoking machines: Control and monitoring.

*ISO 3402: 1991*

Tobacco and tobacco products - Atmosphere for conditioning and testing.

*ISO 3308: 1991*

Cigarettes - Routine analytical cigarette-smoking machine - Definitions and standard conditions.

*ISO 6565: 1983*

Tobacco and tobacco products - Draw resistance of cigarettes and filter rods - Definitions, standard conditions and general aspects.

*ISO 7210: 1983*

Smoking machines for tobacco and tobacco products - Non-routine test methods.

## 4. STANDARD CONDITIONS

### 4.1. *Machine Pressure Drop*

The whole of the flow path between the butt end of the cigarette and the suction mechanism shall offer the least possible resistance and its pressure drop shall not exceed 300 Pa.

### 4.2. *Puff Duration*

The standard puff duration shall be 2.0 s, with a standard deviation of not greater than 0.05 s for individual puffs.

### 4.3. *Puff Volume*

The standard puff volume measured in series with a pressure drop of 1 kPa shall be 35 cm<sup>3</sup> with a standard deviation for individual puffs not greater than 0.15 cm<sup>3</sup>. In one puff duration (2.6.) not less than 95% of the puff volume shall leave the butt end of the cigarette.

### 4.4. *Puff Frequency*

The standard puff frequency shall be one puff every 60 s with a standard deviation for this time not greater than 0.5 s.

### 4.5. *Puff Profile*

The puff profile, when measured on an unlit cigarette, shall be bell-shaped with a maximum between 0.8 s and 1.2 s from the start of the puff. The increasing and decreasing parts of the profile shall not have more than one point of inflection each. The maximum flow rate shall be between 25 cm<sup>3</sup> s<sup>-1</sup> and 30 cm<sup>3</sup> s<sup>-1</sup> (see Annex B). At no point should the direction of flow be reversed.

*Note* : Principles of suction mechanisms using a piston pump to obtain the puff profile are given in Annex A.

### 4.6. *Restricted Smoking*

An analytical smoking machine shall be a restricted smoker.

### 4.7. *Puff Number*

Each individual puff shall be counted and recorded and the puff number rounded off to the nearest one-tenth of a puff based on the puff duration.

### 4.8. *Cigarette Holders*

The standard cigarette holder shall cover 9 mm ± 0.5 mm from the butt end of a cigarette and shall be impermeable to smoke components and to air. The standard cigarette holder shall ensure that the leakage between the cigarette and cigarette holder is not greater than 0.5% of the puff volume.

Either the cigarette holder or the smoke trap shall be equipped with a perforated disc (washer) of plain expanded synthetic rubber, closed cell sponge grade, which obstructs partly the butt end of the cigarette. The synthetic rubber shall have a density of 150 kg/m<sup>3</sup> to 170 kg/m<sup>3</sup>, low swell oil resistance and compression - deflection range of 35 kPa to 63 kPa.

Four labyrinth seals shall be used, the one closest to the butt end (back seal) shall be reversed. The dimensions of the washer and labyrinth seals are given in Figure 1. The washer shall be supported by a structure with a hole in its centre of 4 mm diameter. The assembly shall be constructed so that the cigarette shall be in contact with the washer when the cigarette is inserted to a depth of 9 mm from the sealing annulus of the front labyrinth seal. An example of a suitable assembly is given in Figure 2.

#### **4.9. Cigarette Position**

The angle formed by the longitudinal axis of the cigarette and the horizontal plane shall be as small as possible; it shall not exceed 10° if the centre of the butt end is lower than the centre of the other end and 5° if the centre of the butt end is higher than the centre of the other end.

The cigarette holders shall be arranged so that no cigarette influences the burning of any other cigarette.

#### **4.10. Ashtray Position**

The ashtray shall be placed in a horizontal plane between 20 and 60 mm below the plane of the axes of the cigarettes.

## **5. SPECIFICATION FOR THE ROUTINE ANALYTICAL SMOKING MACHINE**

The smoking machine shall comply with the standard conditions (see 4.1. to 4.10.) and the following special conditions.

#### **5.1. Operating Principle and Puff Profile**

The machine shall include a device to draw a fixed volume of air (puff) through a cigarette. A schematic diagram is shown in Figure 3.

**5.1.1.** The machine shall produce a bell-shaped puff profile (see 4.5.)

**5.1.2.** The machine shall be a restricted smoker (2.3.)

#### **5.2. Reliability and Compensation**

The machine shall contain devices to control the puff volume, the puff duration and the puff frequency.

**5.2.1.** The machine shall possess the mechanical and electrical reliability necessary to meet the standard conditions regarding these parameters (see 4.2., 4.3. and 4.4.) for prolonged periods.

**5.2.2.** The machine shall be capable of sufficient compensation (2.17.).

When the machine has initially been set to give the puff volume of 35 cm<sup>3</sup> without a pressure drop device, a reduction of no more than 1.5 cm<sup>3</sup> shall be observed when the machine is tested with a pressure drop device of 3 kPa.

**5.2.3.** The connecting piping between the smoke trap and the suction source shall offer the least possible resistance to flow. The pressure drop of the total flow path between the butt end of the cigarette and the suction source shall not exceed 300 Pa before smoking (see 4.1.).

**5.2.4.** The total dead volume (2.12.) shall be as small as possible and shall not exceed 100 cm<sup>3</sup>.

**5.3.** *Cigarette Holders and Smoke Traps*

The machine shall contain devices for holding the cigarette and for trapping the smoke produced.

**5.3.1.** The cigarette holders shall be capable of holding the butt end of the cigarette during smoking. The standard conditions relative to the length of butt covered by this device and the airtightness of the seal are given in 4.8.

Labyrinth seals shall be used for attaching cigarettes.

**5.3.2.** Devices shall be provided for attaching cigarette holders to the machine, so that the cigarette holders are held rigidly. A screwed fitting or "O" ring seal is recommended. Rubber tubing is considered to be unsatisfactory.

**5.3.3.** The cigarettes to be smoked shall be attached to the ports or the smoke traps by standard cigarette holders (see 4.8.).

**5.3.4.** The machine shall be designed to hold the cigarettes in the standard position (see 4.9.).

The system shall be designed to prevent losses of smoke components between the butt end of the cigarette and the smoke trap.

**5.3.5.** The cigarette holders shall be arranged so that the sidestream smoke does not affect cigarettes smoked in adjacent holders (see 4.9.). The distance between the centres of adjacent burning zones shall be at least 50 mm.

**5.3.6.** When the smoking machine is used for collecting particulate matter it shall be fitted with a glass fibre filter smoke trap, comprising:

- Filter holders made of an airtight, non-hygroscopic and chemically inert material, preferably transparent, fitted with end cap seals of the same material, able to contain a filter disc of glass fibre material 1 mm to 2 mm thick. The rough filter surface shall face the oncoming smoke. Two examples are given in Figure 4a and Figure 4b.

Different designs of smoke trap can meet this requirement. It is recommended that for smoking machines where 5 cigarettes are smoked per trap the diameter of the glass fibre filter should be 44 mm.

For machines where 20 cigarettes are smoked per trap the diameter of the glass fibre filter should be 92 mm.

- Filter material which shall retain at least 99.9% of all particles having a diameter equal to or greater than 0.3 micrometer of a dioctyl phthalate aerosol at a linear air velocity of 140 mm s<sup>-1</sup>. The pressure drop of the filter assembly shall not exceed 900 Pa at this air velocity. The content of polyacrylate binder shall not exceed 5% (mass/mass).

The filter assembly shall be capable of quantitatively retaining all of the particulate matter in the mainstream smoke produced by the cigarette without loss. In addition, the filter assembly shall be chosen so that the increase in pressure drop of the assembly does not exceed 250 Pa when measured after the smoking run.

- 5.3.7.** Each channel shall have a puff termination device linked to a butt length (mark) sensor and a puff counter. When activated by the sensor the device shall prevent any further drawing of air through the cigarette.

The sensor may be either :

- a) a micro-switch activated by the burning through of a 100% cotton, 40 denier, thread placed on the butt mark; or
- b) a specially shielded infra-red detector.

- 5.3.8.** The machine shall be capable of smoking a wide range of cigarettes of different lengths, diameters and cross-sectional shapes while complying with the standard conditions regarding cigarette butt lengths.

- 5.3.9.** The machine shall be capable of making one or more clearing puffs after the termination of smoking.

#### **5.4.** *Ambient Conditions*

The ambient conditions shall be controlled to ensure that all the cigarettes are smoked under identical conditions with regard to ambient air flow.

The temperature and relative humidity of the ambient conditions shall correspond to those specified in CORESTA Recommended Method N° 21: 1991.

- Temperature:  $22\text{ °C} \pm 2\text{ °C}$

- Relative humidity:  $(60 \pm 5)\%$

The linear air speed around the cigarettes shall be adjustable such that sidestream smoke can be effectively removed.

The design of the enclosure around the smoking machine and of the sidestream smoke extraction system shall provide identical conditions with regard to air flow around the cigarettes for the different designs of smoking machine which conform to the specification in this recommended method. (See CORESTA Recommended Method N° 25: 1991).

#### **5.5.** *Puff Counting*

Each port shall have its own puff counter capable of counting to the nearest 0.1 puff (see 4.7).

#### **5.6.** *Ignition*

Flameless ignition shall be used. The lighters shall light the cigarettes at the first attempt without either touching or pre-charring the cigarette.

#### **5.7.** *Smoking Enclosure*

The smoking process shall be carried out in an enclosure, preferably transparent, which may be an integral part of the smoking machine, or a housing in which the machine can be sited. The enclosures shall be capable of being fitted with an air-extraction device to facilitate the controlled removal of sidestream smoke from the enclosure.

## ANNEX A

### DESCRIPTION OF THE PUFFING MECHANISM OF A PISTON TYPE OF SMOKING MACHINE

(Informative: this annex does not form an integral part of the recommended method.)

The following description defines examples of use of the piston principle but it is not intended to preclude or restrict the future development of smoking machines.

#### **A.1.** *Principle of puffing mechanism*

Examples for piston/crankshaft mechanisms are given in Figures 5a, 5b and 5c.

#### **A.2.** *Special considerations*

##### **A.2.1.** Total swept volume:

The total swept volume is the volume of air displaced when the piston passes from the top dead centre to the bottom dead centre and may be up to 3% greater than the puff volume. A typical example of the resultant swept profile is given in Fig. 6.

##### **A.2.2.** Puff volume:

The puff volume may be controlled by truncating the "skirt" or "tails" of the swept profile using a valve.

#### **A.3.** *Design considerations of puffing mechanism*

It would appear that specifications of  $A$ ,  $r$ ,  $l$  and  $h$  are the most important design considerations. Since  $2Ar$  equals swept volume,  $r$  is automatically fixed and  $l$  and  $h$  determine the shape of the puff. For reasons of symmetry  $l$  and  $h$  should be as large as possible. Therefore, in the manufacture of a piston type of smoking machine, the following should apply:

**A.3.1.** The speed of rotation of the shaft should be constant during puffing, should be fully adjustable and should have fine control.

**A.3.2.** It is desirable that pistons and cylinders be completely interchangeable.

**A.3.3.** The distance  $l$  or  $h$  should be greater than  $10r$ .

**A.3.4.** The piping between the smoke trap and the cylinder should offer the least possible pressure drop (see 5.2.3).

**A.3.5.** In order to ensure that the machine performs according to the specification, incorporation of a mechanism to start or stop the piston at a definite point may be necessary.

## ANNEX B

### DIAGRAMMATIC REPRESENTATION OF A PUFF PROFILE

(Informative: this annex does not form an integral part of the Recommended Method)

**B.1.** *To illustrate certain definitions and certain standard conditions, the puff profile may be described as follows (see Figure 7):*

At time  $t = 0$ , suction may be applied to the cigarette by means of a piston pump. The resulting flow rate  $\phi$  at the butt end of the cigarette varies to give a bell-shaped puff profile. The maximum flow rate  $\phi_m$  is reached at time  $t_m$ .

The flow rate then decreases during the puff duration to reach the value  $\phi_d$  at time  $t_d$  when the puffing source ceases to apply suction, but a pressure differential still exists.

Finally, the flow rate decreases slowly to 0, a value reached at time  $t_e$ .

**B.2.** The standard puff profile has its maximum so that:

$$25 \text{ cm}^3 \text{ s}^{-1} \leq \phi_m \leq 30 \text{ cm}^3 \text{ s}^{-1}$$

at time  $t_m$  so that :

$$0.8 \text{ s} \leq t_m \leq 1.2 \text{ s}$$

The standard puff duration is  $t_d = 2,0 \text{ s}$  and the time  $t_e$  is consequently limited by the standard puff frequency to  $t_e = 60 \text{ s}$ .

The puff volume  $V$  may be calculated on the basis of the shaded area in figure 7 from the formula :

$$V = \int_0^{t_e} \phi(t) dt = A + B = \int_0^{t_d} \phi(t) dt + \int_{t_d}^{t_e} \phi(t) dt$$

The consequence of the standard conditions is the following:

$$V = 35 \text{ cm}^3$$

$$A = \int_0^{t_d} \phi(t) dt \geq 0.95 V$$

FIGURE 1

**CIGARETTE HOLDER – LABYRINTH SEAL AND PERFORATED DISC (WASHER) DIMENSIONAL DETAILS**

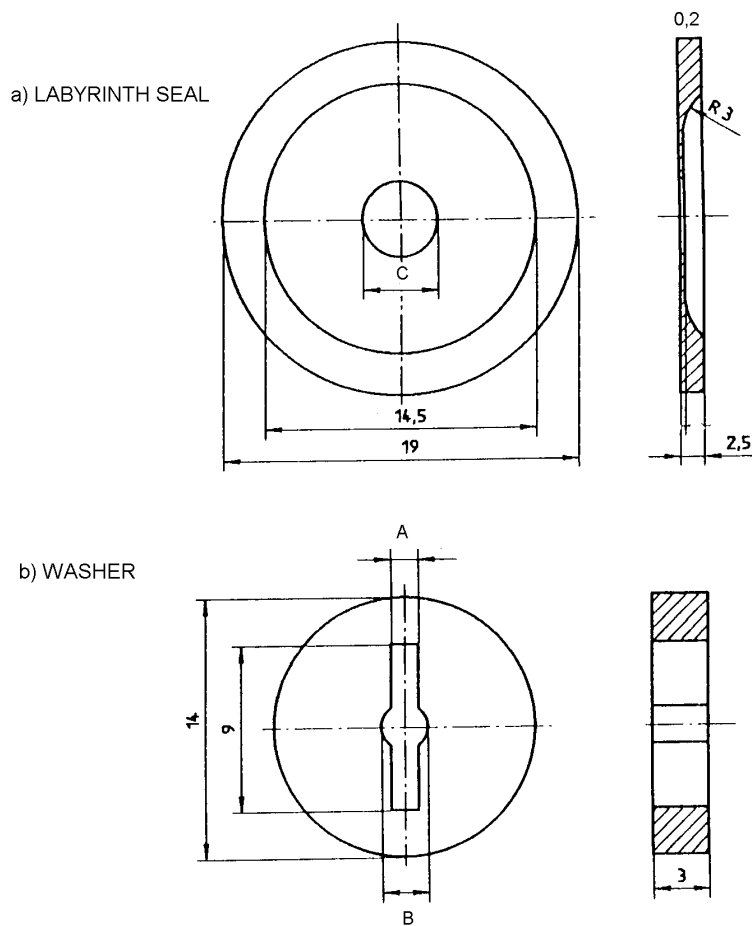

Cigarette Diameter	A	B	C
4.5 - 5.49	1.45	2.5	4.0
5.5 - 6.49	1.70	3.0	4.5
6.5 - 7.49	1.95	3.5	5.5
7.5 - 9.00	2.20	4.0	6.5

All dimensions in mm

FIGURE 2

**CIGARETTE HOLDER – schematic**

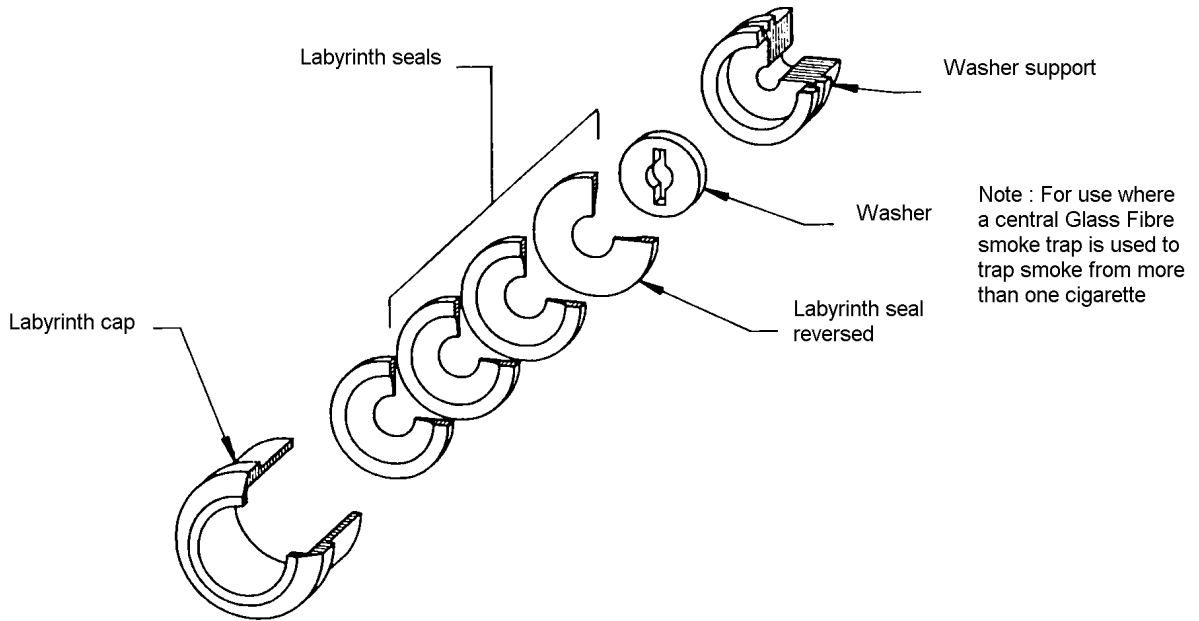

FIGURE 3  
SMOKING MACHINE SCHEMATICS

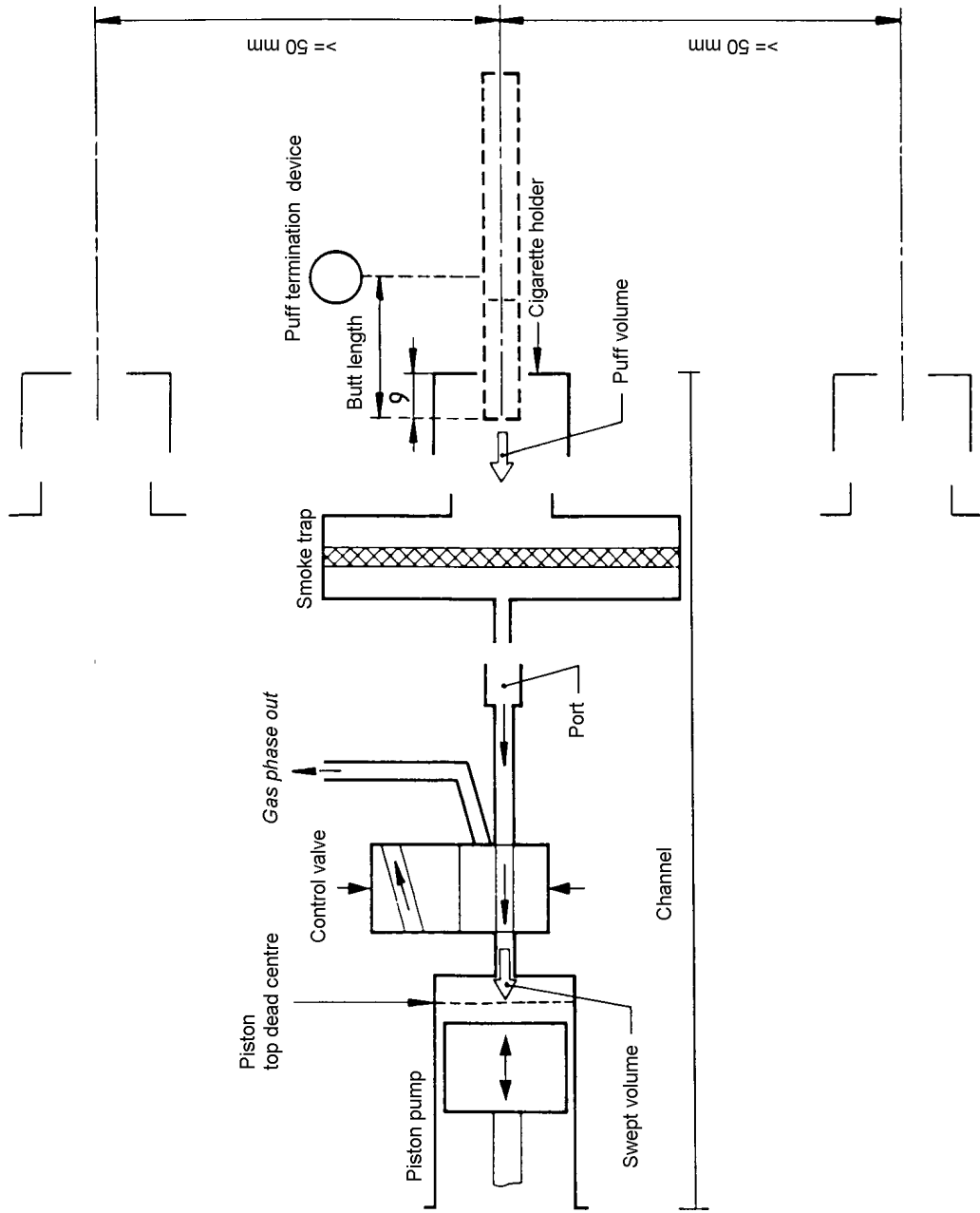
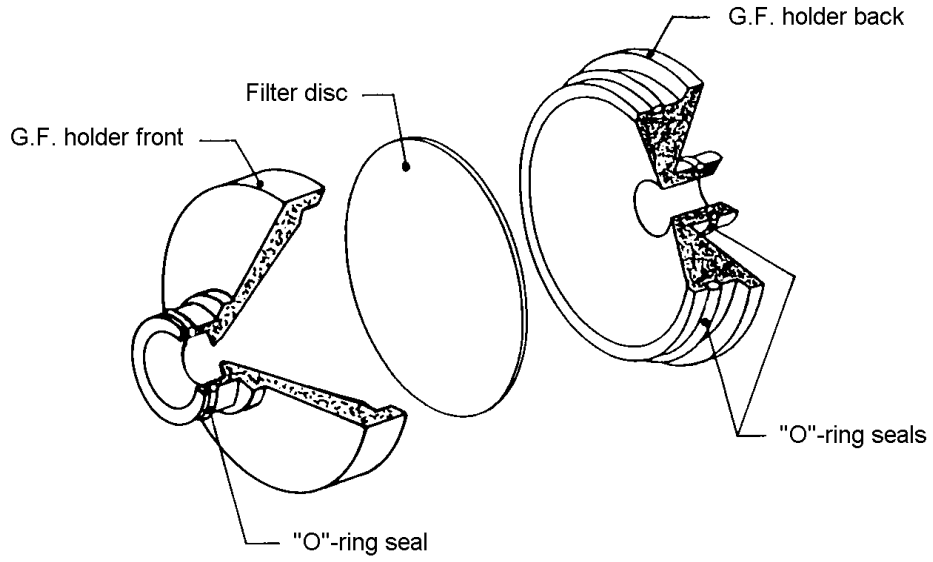

FIGURE 4

**GLASS FIBRE FILTER (G.F.) SMOKE TRAP – schematic – 2 EXAMPLES**

a)



b)

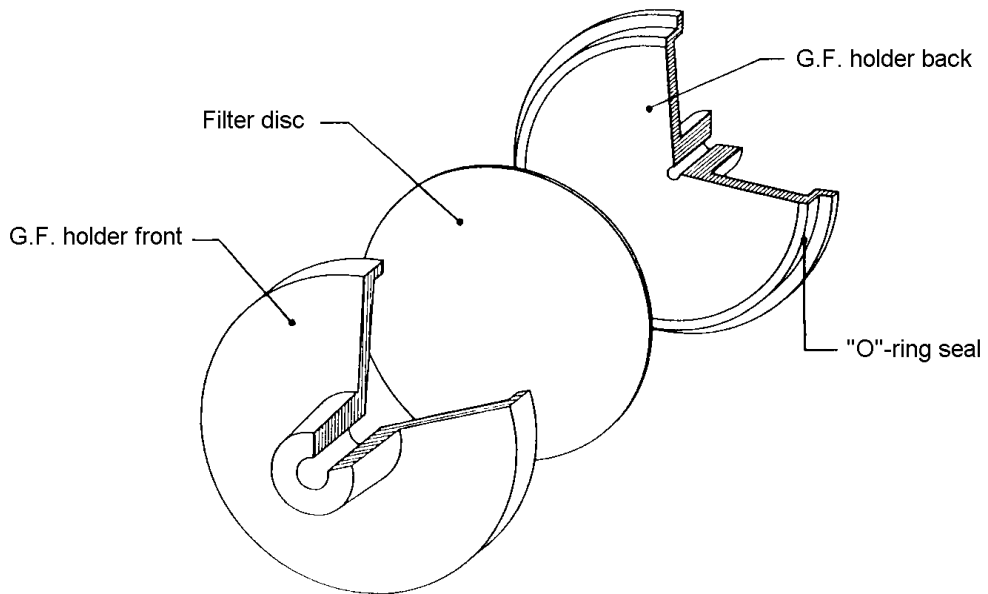
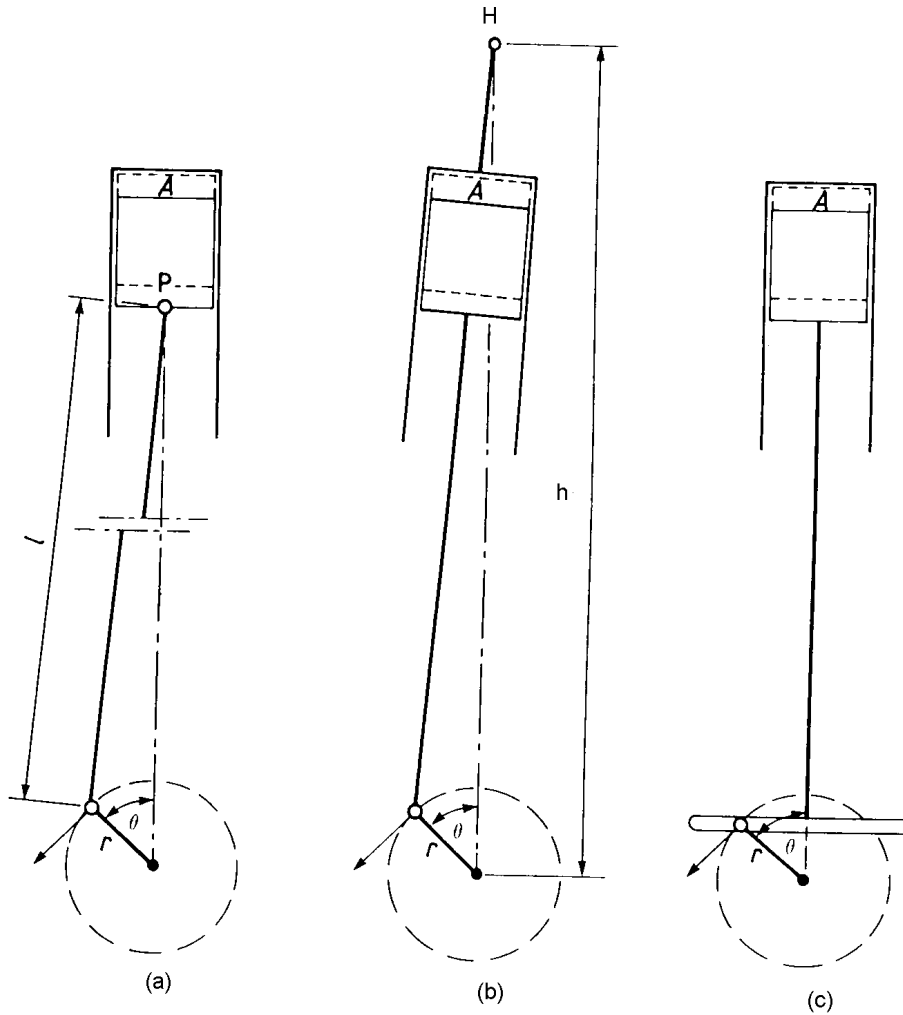

FIGURE 5

EXAMPLE OF PISTON/CRANKSHAFT MECHANISMS



Conventional crankshaft with connecting rod and small end

Rigid piston connected with cylinder pivoted at H

Symmetrical piston movement

- A = area of cross-section
- H.P = pivots
- $l$  = length of connecting rod
- $h$  = distance between crank and pivot H
- $r$  = radius of crank
- $\theta$  = angular displacement of the crankshaft

FIGURE 6

**TYPICAL PUFF PROFILE WITHOUT CIGARETTE (SWEPT PROFILE)**

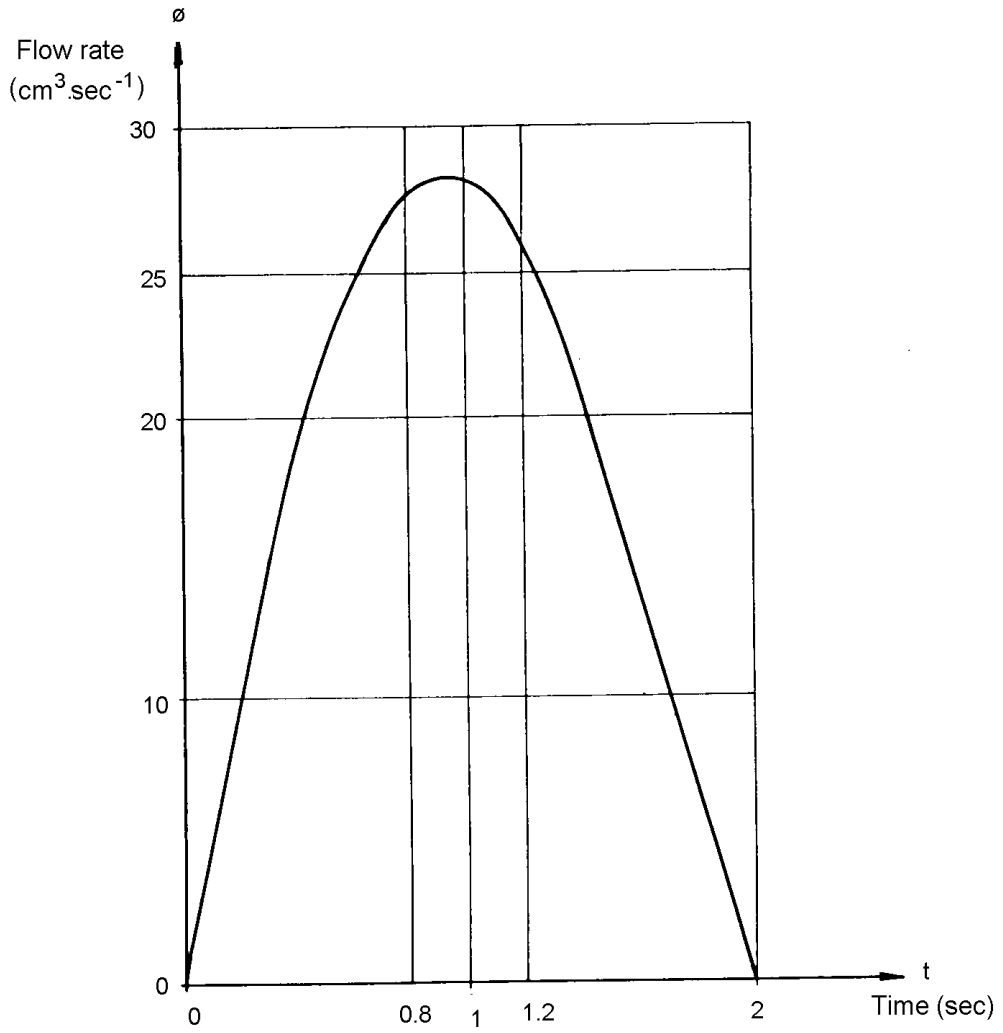

FIGURE 7

DIAGRAMMATIC REPRESENTATION OF A PUFF PROFILE WITH CIGARETTE

