

CORESTA RECOMMENDED METHOD N° 25

AMBIENT AIR FLOW AROUND CIGARETTES IN ROUTINE ANALYTICAL SMOKING MACHINES : CONTROL AND MONITORING

(August 1991)

0. INTRODUCTION

The development of smoking machines has taken place over perhaps 45 years. However because the mechanical configurations which can meet this Recommended Method differ greatly, it has been found from the work of a special Task Force (*), established by CORESTA, that additional specification of the immediate smoking machine environment is necessary. This leads to better reproducibility in the international inter-laboratory comparisons which are often required. It is doubtful if a general mechanical specification can be written to cover all types of smoking machines and so, as well as a general specification, it is necessary to provide examples for the designs most generally used.

There are two principal designs which satisfy CORESTA Recommended Method RM N° 22:

- **type (a)** in which the position of the cigarette in its holder is fixed, *i.e.* adjustments are made by moving the puff termination device ;
- **type (b)** in which the position of the puff termination device is fixed, *i.e.* adjustments are made by moving the cigarette and its holder.

1. FIELD OF APPLICATION

This Recommended Method

- specifies the ambient air velocities surrounding cigarettes in an analytical smoking machine during the smoking process and mechanical design of the enclosures immediately surrounding them;
- specifies the methods of air velocity measurement and the location where air velocity shall be measured.

2. REFERENCES

CORESTA - Recommended Method N° 7: 1991

Determination of nicotine in the main stream smoke of cigarette by gas chromatographic analysis.

(*) The Task Force, composed of members of the CORESTA Smoke and Technology Groups, has conducted collaborative studies in 1988, 1989 and 1990. The studies have already resulted in the production of Recommended Methods N° 21, 22, 23 and 24.

CORESTA - Recommended Method N° 8: 1991

Determination of water in the mainstream smoke of cigarettes by gas chromatographic analysis.

CORESTA - Recommended Method N° 22: 1991

Routine analytical cigarette-smoking machine, specifications, definitions and standard conditions.

CORESTA - Recommended Method N° 23: 1991

Determination of total and nicotine-free dry particulate matter using a routine analytical cigarette-smoking machine - determination of total particulate matter and preparation for water and nicotine measurements.

ISO 10315: 1991

Cigarettes - Determination of nicotine in smoke condensates - Gas chromatographic method.

ISO 10362-1: 1991

Cigarettes - Determination of water in smoke condensates - Part 1: Gas chromatographic method.

ISO 3308: 1991

Cigarettes - Routine analytical cigarette-smoking machine - Definitions and standard conditions.

ISO 4387: 1991

Cigarettes - Determination of total and nicotine-free dry particulate matter using a routine analytical smoking machine.

3. DESIGN OF SMOKING MACHINE ENCLOSURE

Examples of mechanical specifications for the design of suitable enclosures for machines which satisfy CORESTA Recommended Method N° 22 are given.

3.1. *Smoking machine type (a)*

Figures 1 and 2 show schematic designs of the enclosure including the features which shall be incorporated.

3.2. *Smoking machine type (b)*

This type of machine exists with 20 and 8 channels. Features common to both are shown in detail in figure 3. Figure 4 shows a schematic design of the enclosure including the features which shall be incorporated in 20 channel versions. Figure 5 is appropriate to 8 channel versions.

4. AIR VELOCITY MEASUREMENT LOCATIONS

The reference points at which measurement of air velocity shall be made are given. Cigarette holders but not cigarettes shall be in place during measurements. The required measurements shall be made such that the centre of the air velocity meter probe is within ± 2 mm in each plane of the specified position.

4.1. *Smoking machine type (a)*

The air velocity shall be measured at a point on the axis of the cigarette as held in its holder 74 mm towards the end of the cigarette which is to be lit from a datum defined by the position of the butt (mouth) end of the cigarette.

4.2. *Smoking machine type (b)*

4.2.1. The air velocity shall be measured at a point on the axis of the cigarette as held in its holder 40 mm towards the end of the cigarette which is to be lit measured from the position of the puff termination device.

4.2.2. In order to check the uniformity of air flow across the smoking machine, measurements shall be made at least daily at a central port and at a port near each extreme. Additional measurements may be required on installation or relocation of the machine.

5. SPECIFICATION OF THE AIR VELOCITY METER

An air velocity meter capable of an accuracy of at least ± 20 mm s⁻¹ at 200 mm s⁻¹ shall be used. The air velocity measuring equipment shall be capable of integrating air velocity data over a minimum period of 10 s.

The value of a measurement of air velocity shall consist of the average of not less 10 replications of 10 s integrations.

Notes :

1. An omnidirectional probe is preferred.
2. Suitable meters are made by Lambrecht GmbH and TSI Inc.

This information is given for the convenience of users of this Recommended Method and does not constitute an endorsement by CORESTA of the product named. Equivalent products may be used if they can be shown to lead to the same results.

6. STANDARD VALUE OF AIR VELOCITY

The standard value of the air velocity shall be 200 mm s⁻¹.

7. SETTING AND CHECKING AIR VELOCITY

Air velocity shall be set at the standard value at least daily. It is normal practice to measure and if required to adjust the air flow in extraction ducts so that the standard air velocity at the reference point is achieved.

Notes :

1. Laboratory procedures should aim to ensure that the air velocity average during a smoking run lies in the range $200 \text{ mm s}^{-1} \pm 30 \text{ mm s}^{-1}$.
2. For smoking machines type (b), the air velocity measured at an individual port should be within the range $200 \text{ mm s}^{-1} \pm 50 \text{ mm s}^{-1}$.
3. Extreme external atmospheric conditions, *e.g.* high wind velocity, wide relative humidity variations, may affect air flow conditions in smoking machine enclosures. In such circumstances more frequent checks of air velocity should be made.

8. SUBSIDIARY METHOD OF TEST

When it is not possible to obtain and use the equipment to satisfy 6 and 7, confirmation of the achievement of the Standard Smoking conditions can be obtained by test smoking cigarettes the yield of which has been previously determined. If this subsidiary method of test has been used, a note to this effect shall be made in the test report clause 8 CORESTA Recommended Method N° 23, clause 10 Recommended Method N° 7 and clause 11 Recommended Method N° 8.

8.1. *Use of reference cigarette*

- 8.1.1.** A large batch of reference cigarettes should be made and extensively tested according to the method given in CORESTA Recommended Method N° 23. Mean data for nicotine free dry particulate matter and nicotine with confidence levels about the mean should be derived.
- 8.1.2.** A sample of these cigarettes should be smoked according to CORESTA Recommended Method N° 23 and the data compared with the reference values 8.1.1. Air velocity may be judged to be correct if the values obtained from the trial smoking when compared to the reference value for nicotine-free dry particulate matter and/or nicotine are consistent with the repeatability and reproducibility given in 9 of CORESTA Recommended Method N° 23 and/or 9 of Recommended Method N° 7 respectively. In the event of discrepancies greater than these, the air flow controls should be adjusted until the values are consistent.

Note : Care must be taken when using this subsidiary method of test to ensure that all other controls of the smoking machine and smoking process are correctly established before adjusting the flow controls.

FIGURE 1

MACHINE WITH FIXED CIGARETTE POSITION

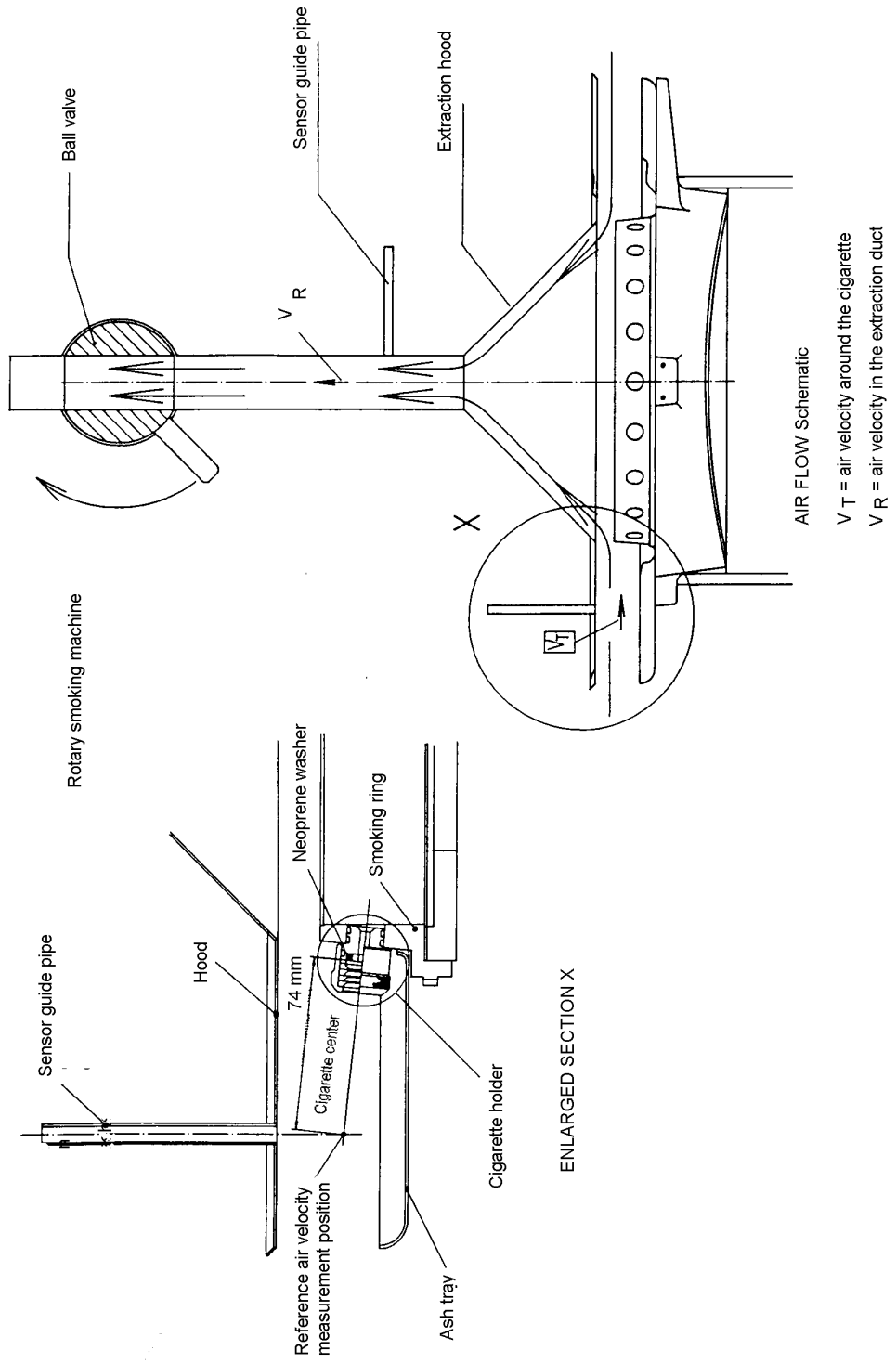

FIGURE 2

EXAMPLE OF AN ENCLOSURE FOR A ROTARY SMOKING MACHINE WITH HOOD

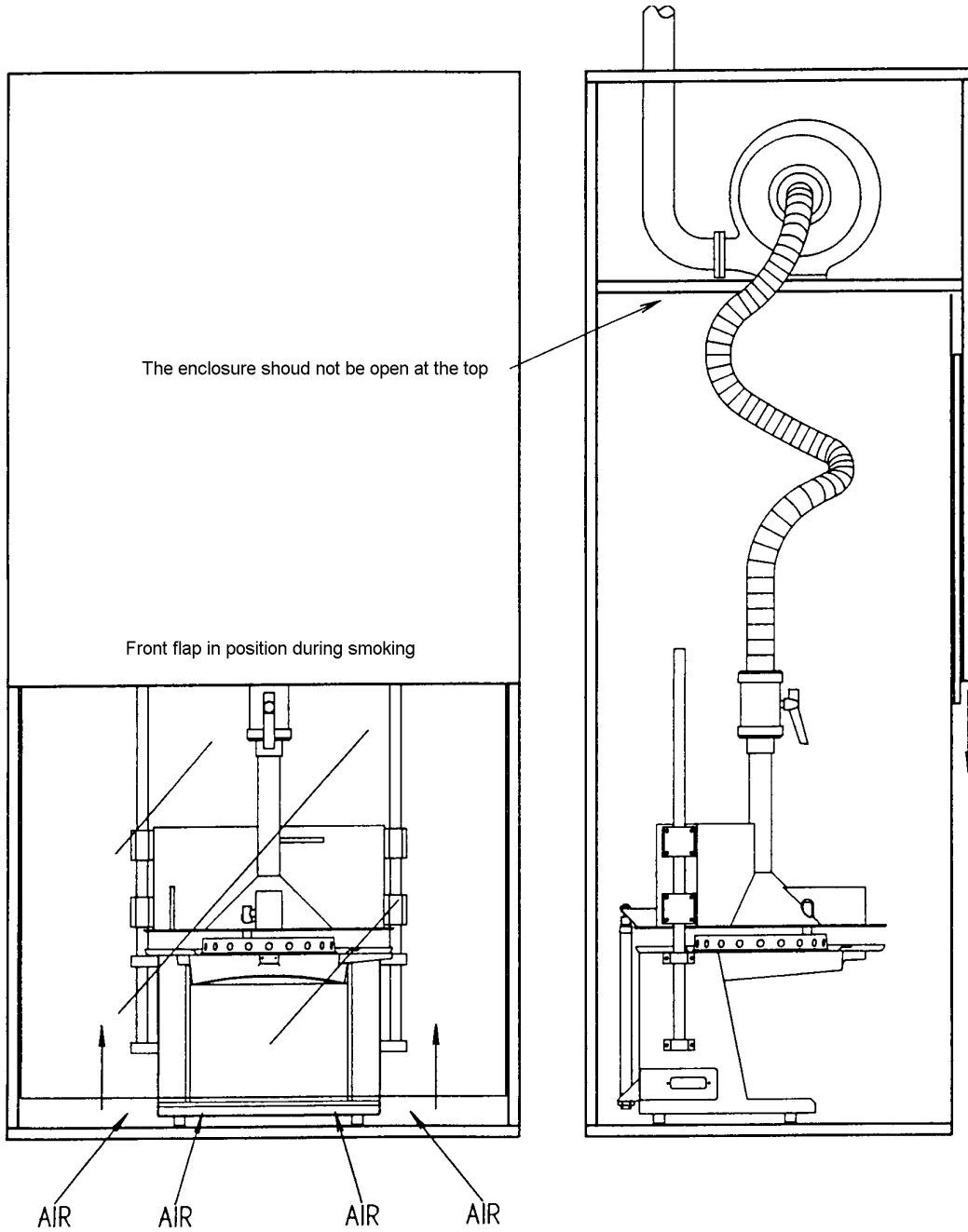
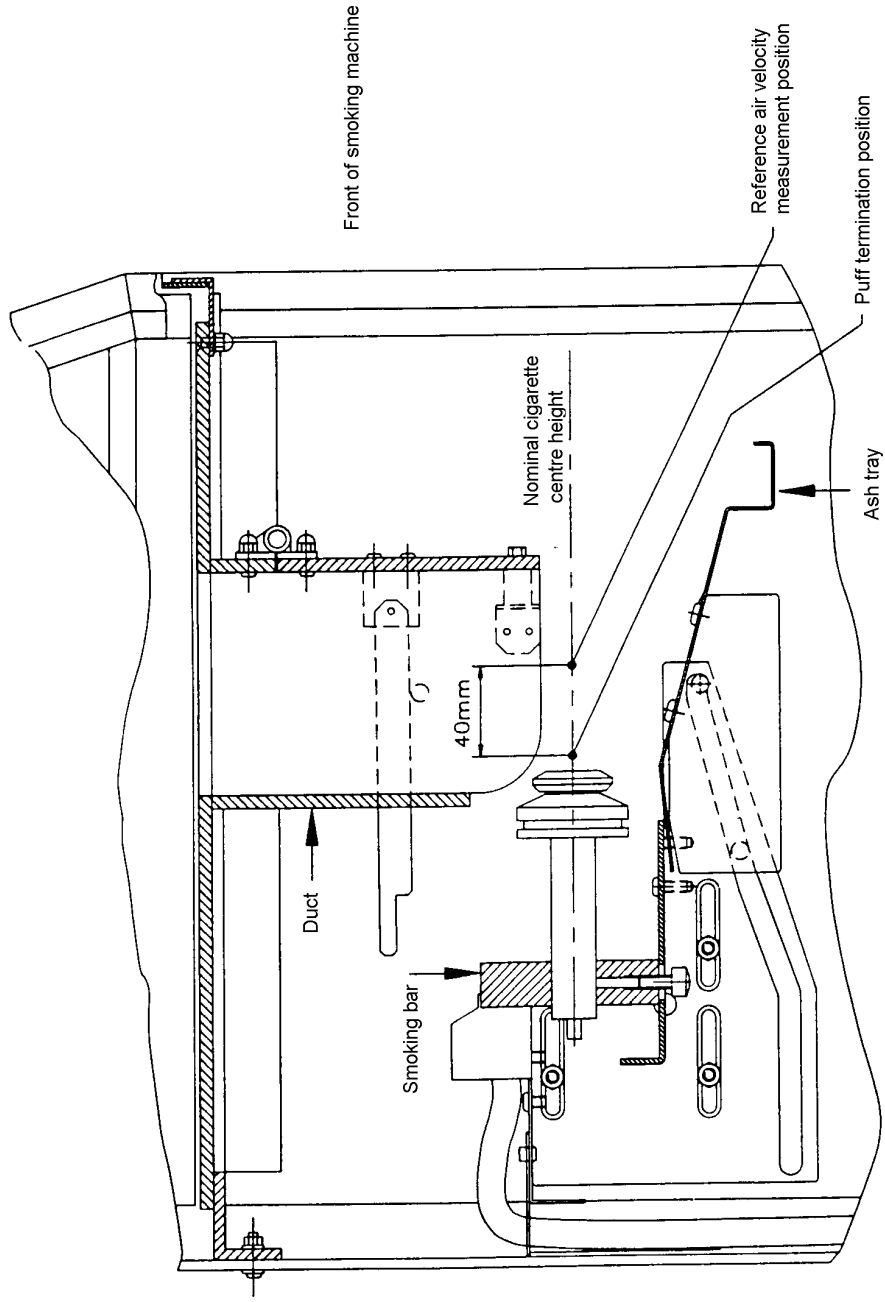

FIGURE 3
MACHINE WITH FIXED PUFF TERMINATION POSITION



VIEW SHOWING RELATIONSHIP BETWEEN
PUFF TERMINATION POSITION, SMOKING
BAR, AND ASH TRAY

FIGURE 4
 SCHEMATIC VIEWS OF 20 CHANNEL LINEAR MACHINE

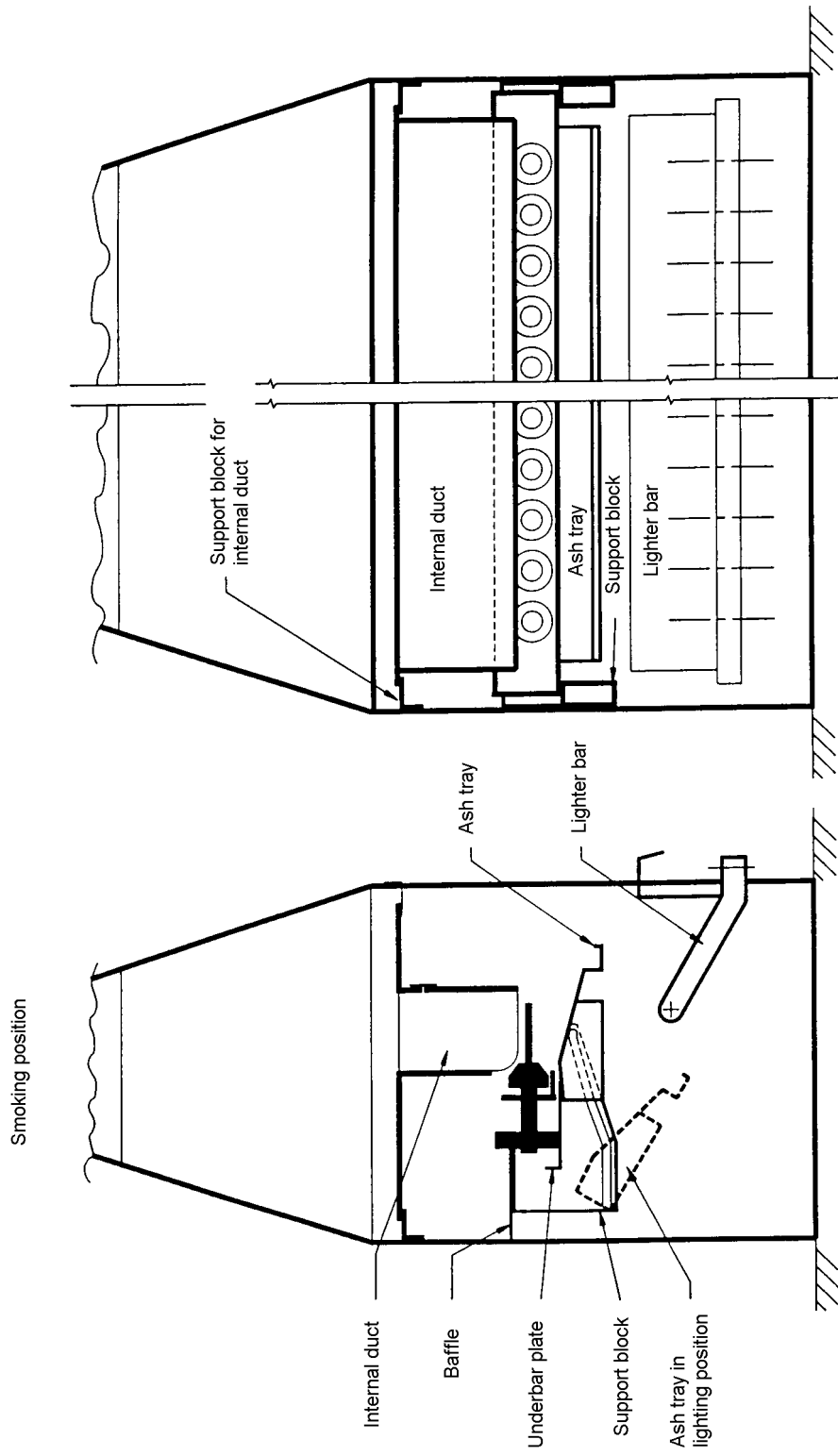

FIGURE 5
SCHEMATIC VIEWS OF 8 CHANNEL LINEAR MACHINE
GENERAL VIEW WITHOUT CARBON MONOXIDE COLLECTION

