

CORESTA RECOMMENDED METHOD N° 35

DETERMINATION OF TOTAL ALKALOIDS (AS NICOTINE) IN TOBACCO BY CONTINUOUS FLOW ANALYSIS

(August 2010)

0. INTRODUCTION

Studies carried out by a CORESTA Task Force between 1989 and 1993 have shown that the two procedures for determination of total alkaloids in tobacco as described in CORESTA Recommended Method N° 20 and the present Method may not produce identical results for some dark tobaccos or those containing significant levels of alkaloids other than nicotine.

The studies have indicated that these differences may be due to the fact that the recoveries and detection sensitivities of the two methods towards the alkaloids other than nicotine are different.

Therefore, when reporting results it is important to specify the method used.

1. FIELD OF APPLICATION

This method is applicable to leaf samples and tobacco blends.

2. REFERENCES

CORESTA Recommended Method N° 20:1968
Determination of alkaloids in manufactured tobacco.

CORESTA Recommended Method N° 39:1994
Determination of the purity of nicotine and nicotine salts by gravimetric analysis - Tungstosilicic acid method.

3. PRINCIPLE

An aqueous (see note 1) extract of the tobacco is prepared and the total alkaloids (as nicotine) content of the extract is determined by reaction with sulphanilic acid and cyanogen chloride. Cyanogen chloride is generated *in situ* by the reaction of potassium cyanide and chloramine T (see appendix 1). The developed colour is measured at 460 nm.

Note 1 : Collaborative studies have shown that this method gives equivalent results for water and 5 % acetic acid extracts. It is recommended that 5 % acetic acid extracts should be used if total alkaloids (as nicotine) and reducing substances (see CORESTA Recommended Method N° 37) or reducing carbohydrates (see CORESTA Recommended Method N° 38) analysis are to be carried out simultaneously.

4. SAFETY PRECAUTIONS

Potassium cyanide is poisonous and irritant, thus all safety precautions must be observed when handling this material. Solutions shall be prepared by a designated responsible person. Gloves and safety glasses shall always be used when making up solutions and bottles of the made-up reagent shall always be carried in a suitable safety carrier. To prevent the escape of vapour into the laboratory, reagent pick-up tubes shall pass through a soda-lime trap into the reagent bottle (see diagram 2).

The cyanide neutralising agents A and B are pumped as shown in the flow diagram (see diagram 1) and mixed in a 2 dm³ Buchner flask with magnetic stirring (see diagram 3). All waste solutions containing cyanogen chloride are run into this flask where conversion to the "Prussian Blue" complex occurs. The contents of the Buchner flask are allowed to over-flow into a storage flask, the contents of which are stored overnight in a fume cupboard and then disposed of as waste.

Suitable cyanide poisoning treatment kits are available from laboratory suppliers and shall be located in the vicinity of the analyzer to be used by a competent person.

5. REAGENTS

All reagents shall be used according to good laboratory practice and existing national regulations.

5.1 *Brij 35 Solution (Polyoxyethylene Lauryl Ether)*

Add 1 dm³ distilled water to 250 g Brij 35, warm and stir until dissolved.

5.2 *Buffer Solution A*

Dissolve 2.35 g sodium chloride (NaCl) and 7.60 g sodium tetraborate (Na₂B₄O₃·10H₂O) in distilled water. Transfer to a 1 dm³ volumetric flask, add 1 cm³ Brij 35 solution (5.1) and dilute to volume with distilled water. Filter the solution through a Whatman N° 1 (or equivalent) filter paper before use.

5.3 *Buffer Solution B*

Dissolve 26 g anhydrous disodium hydrogen orthophosphate (Na₂HPO₄), 10.4 g citric acid (COH(COOH)(CH₂COOH)₂·H₂O) and 7 g sulphanilic acid (NH₂C₆H₄SO₃H)₂ in distilled water, transfer to a 1 dm³ volumetric flask, add 1 cm³ Brij 35 solution (5.1) and dilute to volume with distilled water. Filter the solution through a Whatman N° 1 (or equivalent) filter paper before use.

5.4 *Chloramine T Solution (N-chloro-4-methyl benzenesulphonamide sodium salt), (CH₃C₆H₄SO₂N(Na)Cl·3H₂O)*

Dissolve 8.65 g chloramine T in distilled water, transfer to a 500 cm³ volumetric flask and dilute to volume with distilled water. Filter the solution through a Whatman N° 1 (or equivalent) filter paper before use.

5.5 *Cyanide Neutralising Solution A*

Dissolve 1 g citric acid (5.3) and 10 g ferrous sulphate (FeSO₄·7H₂O) in distilled water and dilute to 1 dm³.

5.6 Cyanide Neutralising Solution B

Dissolve 10 g anhydrous sodium carbonate (Na_2CO_3) in distilled water and dilute to 1 dm^3 .

5.7 Potassium Cyanide Solution (KCN)

CARE: POTASSIUM CYANIDE IS EXTREMELY TOXIC! SEE SAFETY PRECAUTIONS.

In a fume cupboard, weigh 2 g potassium cyanide into a 1 dm^3 beaker. Add 500 cm^3 distilled water and stir (magnetic stirrer) until all of the solid has dissolved. Store in a brown glass bottle.

5.8 Nicotine Hydrogen Tartrate ($\text{C}_{10}\text{H}_{14}\text{N}_2(\text{C}_4\text{H}_6\text{O}_6)_2 \cdot 2\text{H}_2\text{O}$) for the Preparation of Standards

5.9 Standard Nicotine Solutions

5.9.1 Check the purity of the nicotine hydrogen tartrate according to CORESTA Recommended Method N° 39.

5.9.2 Stock Solution: Weigh, to the nearest 0.0001 g, approximately 1.3 g of nicotine hydrogen tartrate in distilled water and dilute to 250 cm^3 in a volumetric flask. This solution contains approximately 1.6 mg nicotine per cm^3 . Store in a refrigerator. Prepare a fresh solution every month.

5.9.3 Working Standards: From the stock solution produce a series of at least five calibration solutions whose concentrations cover the range expected to be found in the samples e.g. 0.04-0.80 mg nicotine per cm^3 . Calculate the exact concentration for each standard taking into account the purity of the nicotine hydrogen tartrate. Store in a refrigerator. Prepare fresh solutions every two weeks.

Note 2 : The method can also be standardized by using nicotine or other nicotine salts of known purity. In this case an amount equivalent to the above used nicotine hydrogen tartrate shall be used.

6. APPARATUS

6.1 The necessary general laboratory equipment, for the preparation of samples, standards and reagents.

6.2 Continuous flow analyzer (see diagram 1) consisting of:

- Sampler
- Proportioning pump
- Dialyser
- Delay coils
- Colorimeter (or equivalent) with 460 nm filter(s)
- Recorder

6.3 Coil for cyanogen chloride generation

A commercially available microbore mixing coil can be used for the *in situ* generation of cyanogen chloride. Alternatively a five turn mixing coil can be prepared (see appendix 2)

7. ANALYSIS OF TOBACCO SAMPLES

- 7.1 Prepare the tobacco for analysis by grinding (the sample should totally pass through a 1 mm sieve) and determine the moisture content. If the tobacco is too wet for grinding it can be dried at a temperature not exceeding 40°C.
- 7.2 Weigh, to the nearest 0.0001 g, approximately 250 mg of the tobacco in a 50 cm³ dry conical flask. Add 25 cm³ distilled water, stopper the flask and shake for 30 minutes.
- 7.3 Filter the extract through a Whatman N° 40 (or equivalent) filter paper, reject the first few cm³ of the filtrate, then collect the filtrate in an analyzer cup.
- 7.4 Run the samples and standards through the system in the normal manner (*e.g.* priming with 6 tobacco extracts, calibration standards and samples with 1 intermediate calibration solution after every 6 samples). If sample concentrations lie outside the range of the standards, the samples shall be diluted and run again.

8. CALCULATION

- 8.1 Plot a graph of peak height against equivalent nicotine concentrations for all the calibration solutions.
- 8.2 Calculate the percentage nicotine (dry weight basis) in the tobacco using the formula:

$$\% \text{ Nicotine (dwb)} = \frac{c \times V \times 100}{m} \times \frac{100}{100 - M}$$

c is the nicotine concentration, expressed in milligrams per millilitre, obtained from the calibration curve (8.1);

V is the volume, in millilitres, of extract prepared (7.2) (normally 25 millilitres);

m is the mass, in milligrams, of the sample (7.2);

M is the moisture content, expressed as percentage by mass, of the tobacco (7.1).

The test result shall be expressed to two decimal places.

Notes :

- 3 When using 5 % acetic acid extracts the standard nicotine solutions (5.9) must be made up with 5 % acetic acid and the wash cycle must be with 5 % acetic acid.
- 4 If this method is performed simultaneously with CORESTA Recommended Method N° 36, CORESTA Recommended Method N° 37 or CORESTA Recommended Method N° 38 combined standards may be prepared.

9. REPEATABILITY AND REPRODUCIBILITY

9.1 An international collaborative study involving 12 laboratories and 3 samples conducted in 1993 showed that when single grades of tobacco were analyzed by this method, the following values for repeatability (r) and reproducibility (R) were obtained.

The difference between two single results found on different extractions by one operator using the same apparatus within a short time interval (the time it takes to analyze 40 sample cups) and without recalibration of the equipment during the time of analysis will exceed the repeatability value (r) on average not more than once in 20 cases in the normal and correct operation of the method.

Single results reported by two laboratories will differ by more than the reproducibility value (R) on average not more than once in 20 cases in the normal and correct operation of the method.

Data analysis gave the estimates as summarized in table 1 and 2.

TABLE 1 : Extraction with Water (1993 Data)

Tobacco Type	Mean Content of Nicotine % (dwb)	Repeatability Conditions r	Reproducibility Conditions R
Oriental	1.17	0.05	0.19
Flue-Cured	2.90	0.08	0.41
Burley	3.97	0.12	0.55

TABLE 2 : Extraction with 5 % Acetic Acid (1993 Data)

Tobacco Type	Mean Content of Nicotine % (dwb)	Repeatability Conditions r	Reproducibility Conditions R
Oriental	1.17	0.07	0.21
Flue-Cured	2.90	0.11	0.67
Burley	3.97	0.13	0.97

For the purpose of calculating r and R, one test result was defined as the yield obtained from analyzing a single extract once.

9.2 During 2005 the CORESTA Scientific Commission sanctioned the CORESTA Routine Analytical Chemistry Sub-group to carry out a collaborative study to confirm these r & R values. This international study involved 17 laboratories and 6 samples and was conducted during 2006. The resulting data are to be found in Table 3.

TABLE 3 Results from the 2006 RAC Collaborative Study

Tobacco Type	Mean Content of Nicotine % (dwb)	Repeatability conditions r	Repeatability coefficient of variation r CV	Reproducibility conditions R	Reproducibility coefficient of variation R CV
Flue-Cured Sample A	3.19	0.17	5.3	0.53	16.6
Flue-Cured Sample B	2.86	0.09	3.2	0.47	16.4
Flue-Cured Sample C	0.70	0.03	4.3	0.16	22.9
Burley Sample D	3.30	0.12	3.6	0.67	20.3
Burley Sample E	1.51	0.08	5.3	0.32	21.2
Flue-Cured Sample F	0.69	0.03	4.4	0.12	17.4

NOTE: This CRM recommends that equivalent results are obtained when either water or 5% acetic acid are used as the extraction solvents and therefore the results from this study were not segregated in the subsequent data analysis. A plot comparing this data to that of the original study can be found below:

Comparison of r and R Results from the 1993 and 2006 Studies

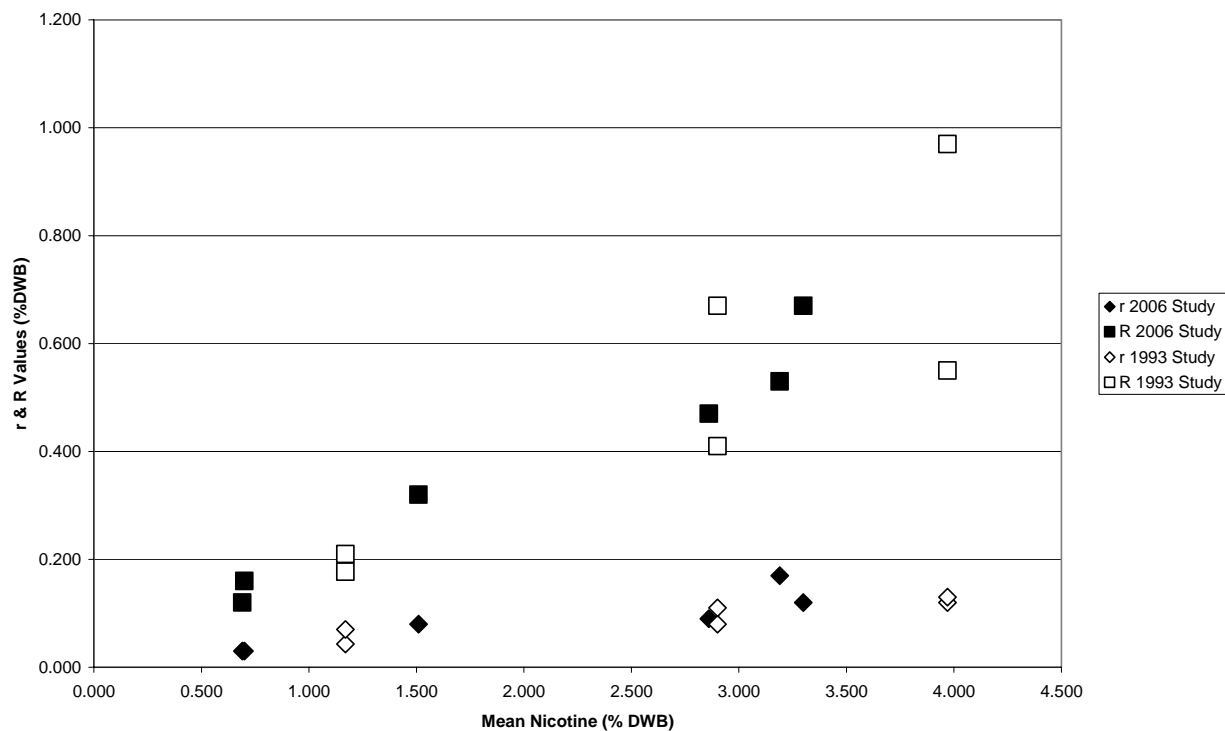

APPENDIX 1

Several collaborative studies, carried out by a CORESTA Task Force during 1989 and 1990, have shown that two other procedures give equivalent results to the Recommended Method. It may be necessary to use one of these alternative procedures, if so, the following comments should be considered before use:

- Cyanogen chloride can be alternatively generated *in situ* by the reaction of potassium thiocyanate and sodium hypochlorite. In order for this reaction to be successful the sodium hypochlorite must have an available chlorine content of 10 % - 14 % (m/m). It has been found that sodium hypochlorite with this amount of available chlorine is sometimes difficult to obtain.
- Cyanogen bromide in reaction with aniline can also be used in the determination of total alkaloids. Because of the hazardous nature of the cyanogen bromide, some countries have found problems with the importation and use of this substance.

APPENDIX 2

Preparation of a Microbore Five Turn Mixing Coil

1. Loop a standard orange-white (0.64 mm id) pump tube 5 times around a glass tube (*e.g.* test tube, glass rod) with an external diameter of approximately 12 mm.
2. While holding the loops in place brush them thoroughly with cyclohexanone.
3. Use adhesive tape to hold the loops in place while the cyclohexanone sets the tubing, (about 10 hours).
4. Remove the glass tube from the coil.

DIAGRAM 1 RM35

Total Alkaloids (as nicotine)

(Technicon part numbers only given for information)
 (Sample and wash times only intended as a guide)

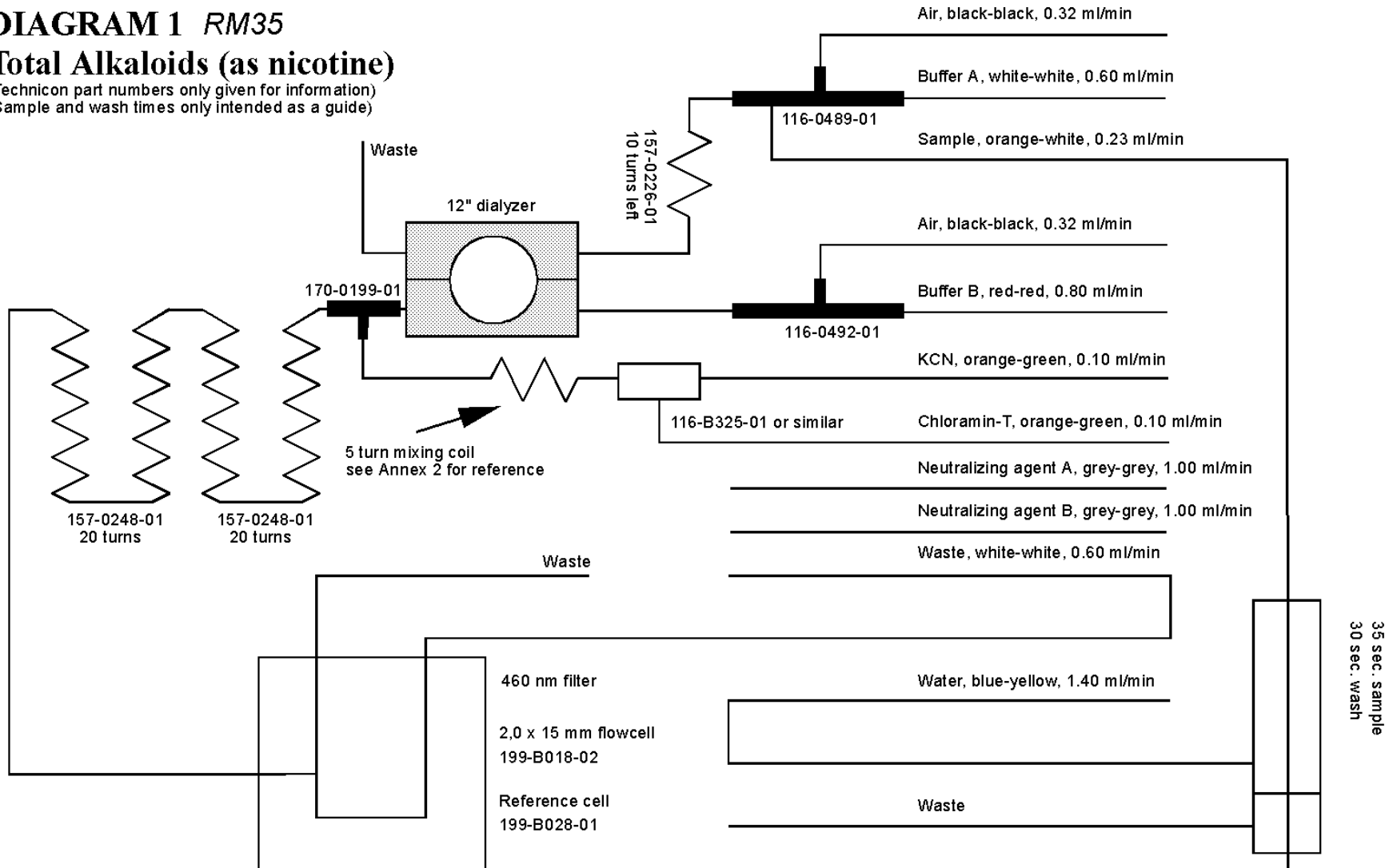

DIAGRAM 2
Soda-Lime Trap

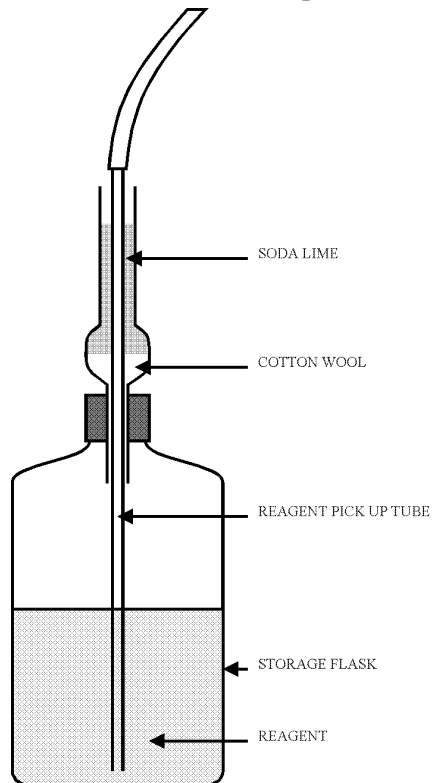
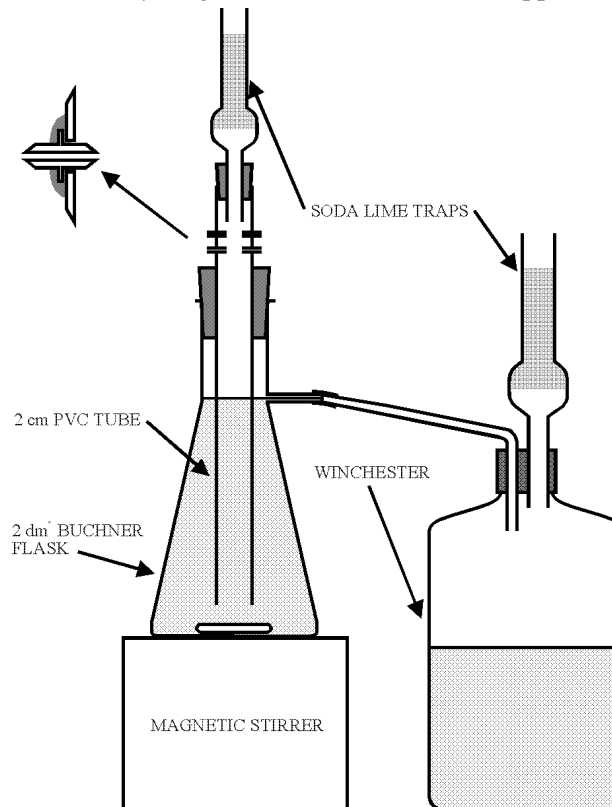

DIAGRAM 3
On-Line Cyanogen Chloride Destruction Apparatus



The apparatus consists of a 2 dm³ Buchner flask on a magnetic stirrer, with a 2 cm diameter PVC tube inserted into it, through a rubber bung, such that the tube is just above the magnetic follower in the flask. Four holes are drilled in the tube and nipples attached by gluing into position. The pullback line and the debubble line containing the cyanogen chloride are attached to the nipples, together with the two neutralising agents. This arrangement ensures that the cyanogen chloride has to pass down the tube and through the bulk of the flask before overflowing to waste, thus ensuring complete neutralisation.