

The assessment of the mutagenic potential of 3R4F mainstream cigarette smoke using multiple Ames strains

Poster Number STPOST 20

David Thorne¹; Joanne Kilford²; Michael Hollings²; Annette Dalrymple¹; Mark Ballantyne²; Clive Meredith¹; Debbie Dillon¹

Affiliations: ¹Group R&D, British American Tobacco, Southampton, United Kingdom. ²Covance Laboratories Ltd, Harrogate, North Yorkshire, United Kingdom.

Corresponding author: David_Thorne@BAT.com

Introduction

The development of whole smoke exposure systems has been driven by the fact that traditional smoke exposure techniques are based on the particulate phase of tobacco smoke and not the complete whole smoke aerosol. To overcome these challenges, whole smoke exposure systems have been developed which expose cell cultures to diluted tobacco smoke and capture the full interactions of both smoke phases ¹. Furthermore, standard methodologies, governed by regulatory guidelines are not necessarily compatible with complex aerosols, including cigarette smoke.

Aim

To develop a modified version of the Ames reverse mutation assay suitable for whole smoke exposure, using a scaled-down 35mm plate format to assess 10 Ames strains for their compatibility with smoke exposure.

Materials and Methods

Cigarette Smoke Generation

A Vitrocell® VC 10 Smoking Robot (Serial Number VC10/090610) was used to expose bacteria to mainstream cigarette smoke generated from 3R4F reference cigarettes (Fig 1). Cigarettes were conditioned according to ISO 3402:1999 and smoked according to ISO 3308:2012, with an 8 second exhaust. Mainstream cigarette smoke was passed into a constant flow of diluting air set at varying flow rates (1-12 L/min) to achieve different concentrations. The diluted smoke was drawn through the modules using a constant vacuum of 5.0mL/min for all experiments.

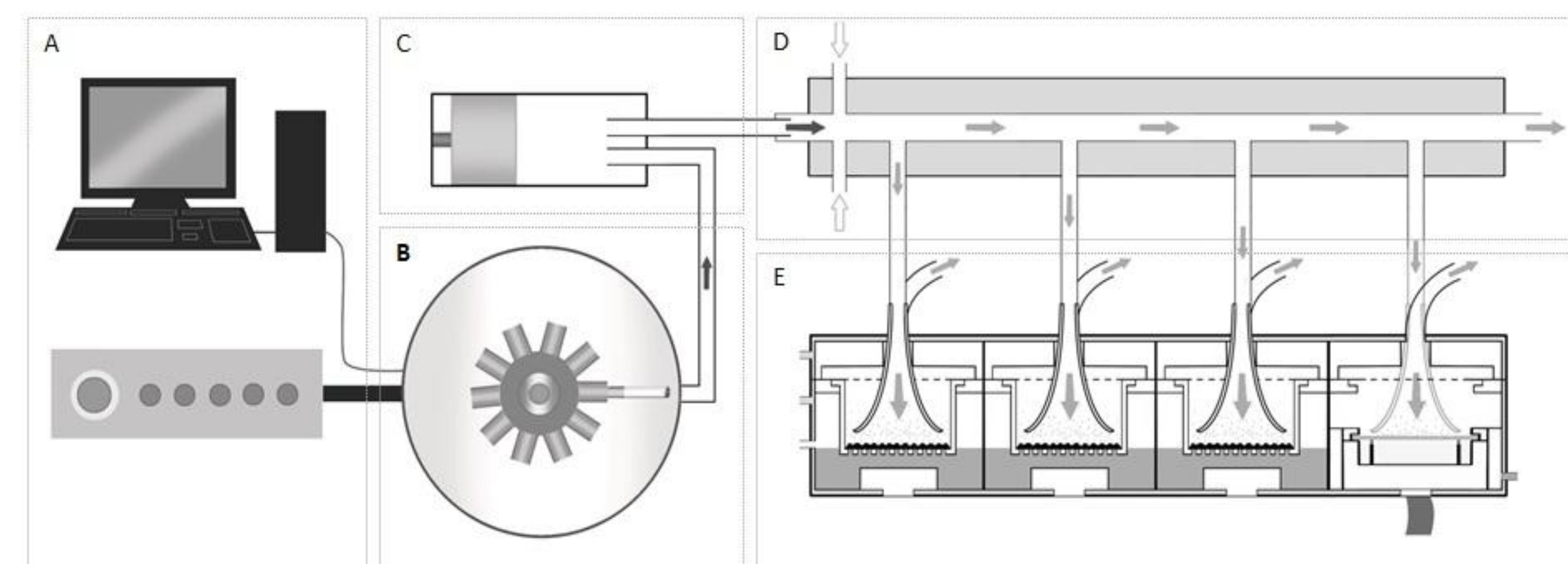

Figure 1: A schematic representation of the VC 10 smoke exposure system. [A] Computer, software and air-flow controller. [B] Smoking Robot carousel where cigarettes are loaded and smoked. [C] Piston/syringe, which draws and delivers mainstream cigarette smoke to the dilution system. [D] Dilution and transit of whole smoke occurs in the dilution bar, of which multiple bars can make up the dilution system. [E] Smoke is sampled from the dilution system into the exposure module through negative pressure applied via a vacuum pump at 5.0 mL/min.

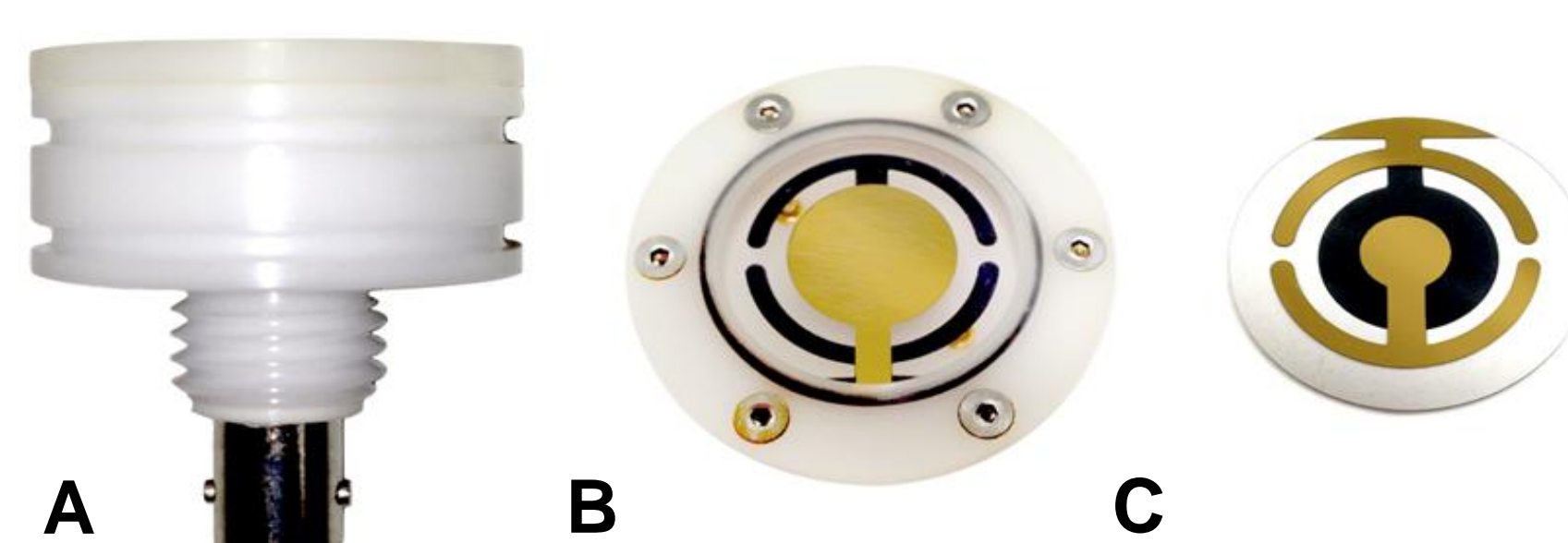

Figure 2: A Quartz crystal microbalance (QCM). Housing unit [A] side view and [B] top view; [C] QCM crystal (underside) 25 mm ø

References

- Thorne, D., Adamson, J. A review of cigarette smoke exposure systems. *Experimental and Toxicologic Pathology* 2013; 65: 1183-1193
- Adamson, J., Thorne, D., Dalrymple, A., Dillon, D., Meredith, C. Cigarette smoke deposition in a Vitrocell® exposure module: real-time quantification *in vitro* using quartz crystal microbalances. *Chemistry Central Journal* 2013; 7:15
- Kilford, J., Thorne, D., Payne, R., Dalrymple, A., Clements, J., Meredith, C., Dillon, D. A method for assessment of the genotoxicity of mainstream cigarette-smoke by use of the bacterial reverse-mutation assay and an aerosol-based exposure system. *Mutation Research* 2014, 769; 20-28

Measurement of Particulate dose

A QCM (Fig 2) was placed in the fourth position of the exposure module for all whole smoke exposures in order to quantify the dose delivered by measuring deposition of particulate mass. At the end of the whole smoke exposure period, the final deposited mass reading on each QCM was recorded once a plateau in the deposition curve was observed ².

Ames Assay

Nine strains of *S. typhimurium* (TA98, TA100, TA1535, TA1537, YG1024, YG1042, TA97, TA102 and TA104) and one strain of *E. coli* (WP2 *uvrA* pKM101) were assessed for their compatibility with whole smoke exposure using a scaled-down 35mm plate format ³. All exposures were completed in the presence and absence of S-9 (Fig 3, 4, 5). Approximately 2x10⁷ cells were plated onto 35 mm Vogel-Bonner agar plates using spread plate methodology such that bacteria were exposed at an air-agar interface. Plates were exposed to a total of 3 cigarettes smoked over 24 minutes (8 puffs per cig). Where no response was observed following 24 minute exposure, exposures were also performed using 8 cigarettes smoked over 64 minutes. A response was deemed positive if a reproducible, concentration-related increase in revertant numbers was observed of at least 2-fold (3-fold for <10 spontaneous revertants) above the concurrent air control, that was significant at the 1% level ($p \leq 0.01$) using Dunnett's test. For TA1535 that has very low spontaneous revertant numbers (0-5 revertants/plate), a positive response was also required to have a minimum of 10 induced revertants.

Results

24 minutes exposure – L/min

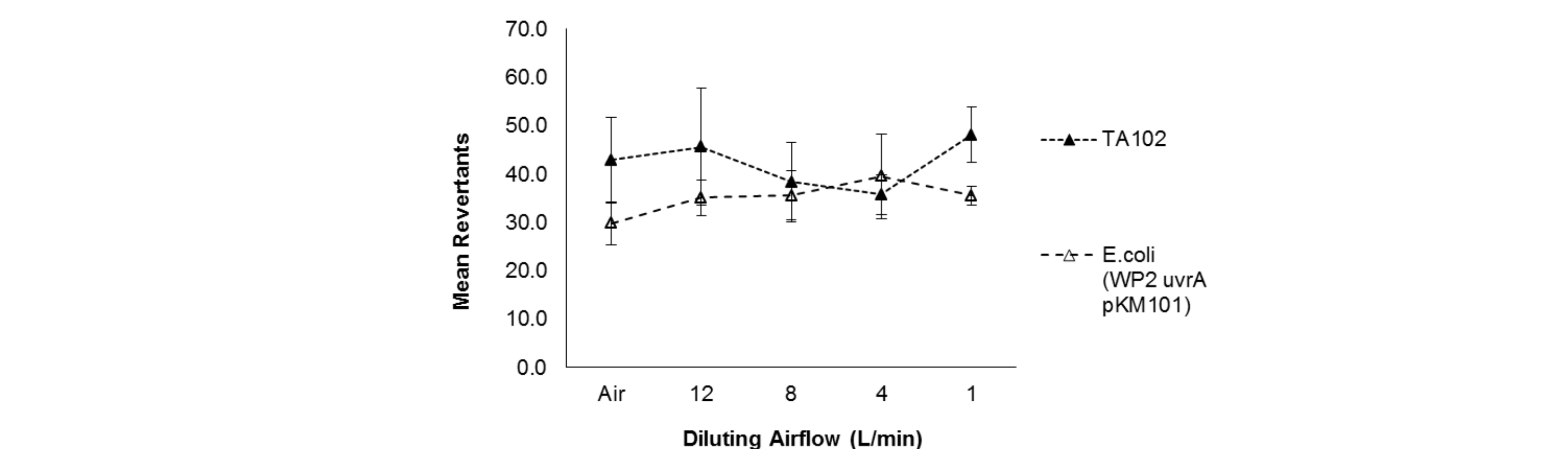
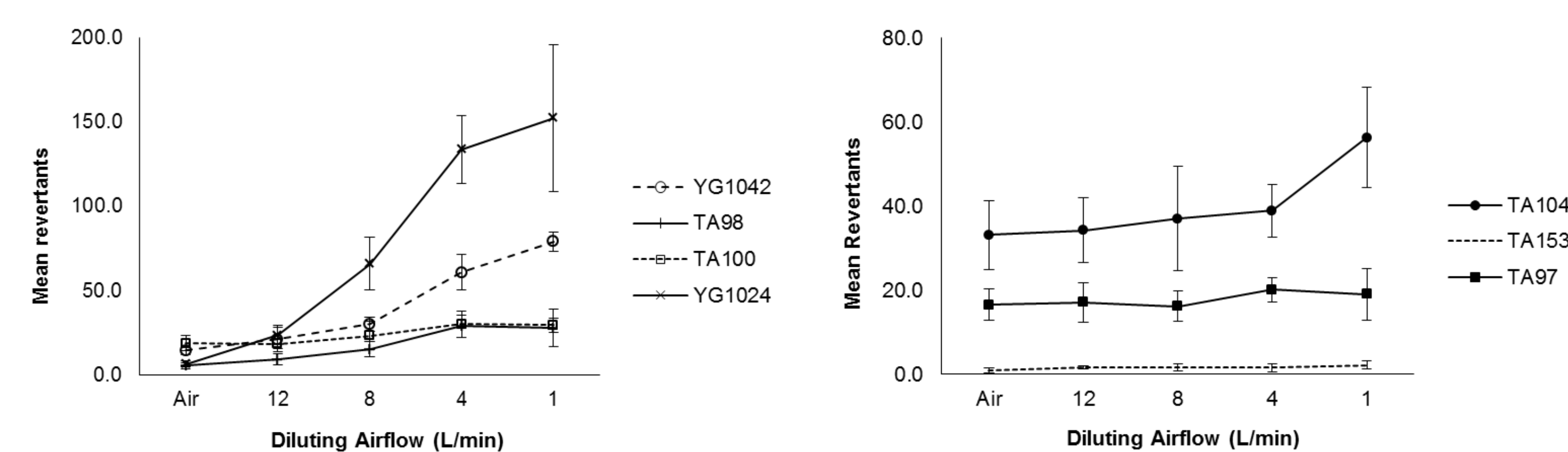

Figure 3: Responses for strains TA98, TA100, YG1024, YG1042, TA1535, TA97, TA102, TA104 and *E. coli* following a 24 minute exposure to 3R4F mainstream cigarette smoke. Positive responses were observed in TA98, TA100, YG1024, YG1042 and TA104. No response was observed in strains TA1535, TA97, TA102 and *E. coli* (WP2 *uvrA* pKM101).

64 minute exposure – L/min

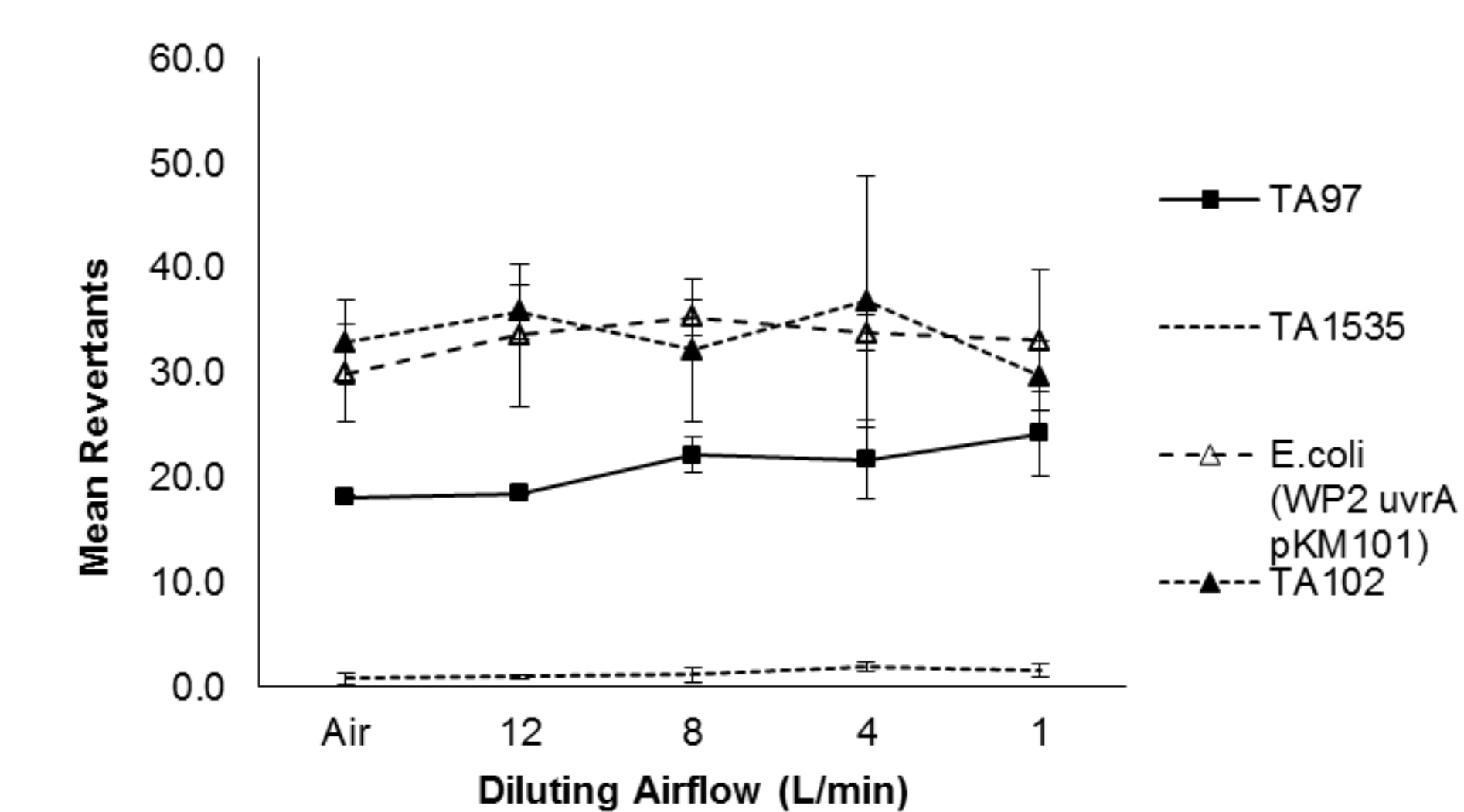

Figure 4: Strains that did not respond following 24 minute exposure to 3R4F mainstream cigarette smoke were also assessed using 64 minute exposure. All strains remained non-responsive.

24 minute exposure – µg/cm²

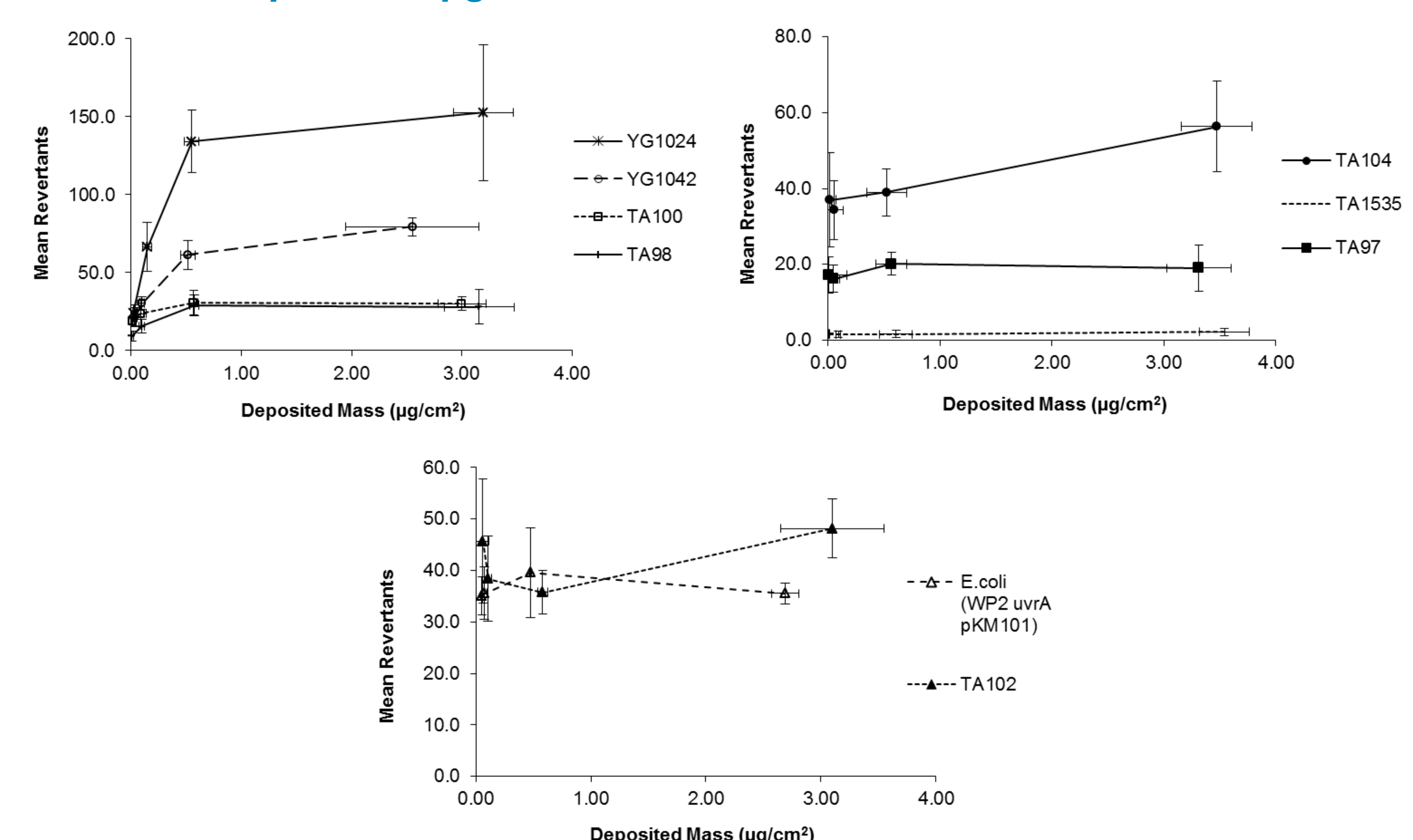

Figure 5: 24 minute mean revertant data presented as a function of deposited mass obtained *in situ* of exposure.

Discussion and Conclusions

- TA98, TA100, YG1024, YG1042 and TA104 were deemed responsive to cigarette smoke (24 mins)
- TA102, *E. coli*, TA1535 and TA97 were deemed non-responsive to cigarette smoke (24 and 64 minutes)
- TA1535 and TA1537 demonstrated low spontaneous revertant numbers (0-5 revertants/plate) when scaled down to the 35mm plate methodology. TA97 was selected for whole smoke exposure as an acceptable alternative to strain TA1537. As no alternative strain is available for TA1535 this was included but a more rigorous evaluation criteria were applied to minimise the risk of false-positives.
- Based on the results from the work, we propose a battery of Ames strains can be employed in a regulatory-style format for the assessment of the mutagenic potential of cigarette smoke or alternative aerosol-based tobacco products.

Related Publications

- Thorne, D., Adamson, J. **A review of cigarette smoke exposure systems.** Experimental and Toxicologic Pathology 2013; 65: 1183-1193
- Adamson, J., Thorne, D., Dalrymple, A., Dillon, D., Meredith, C. **Cigarette smoke deposition in a Vitrocell® exposure module: real-time quantification *in vitro* using quartz crystal microbalances.** Chemistry Central Journal 2013; 7:15
- Thorne, D., Kilford, J., Payne, R., Adamson, J., Scott, K., Dalrymple, A., Meredith, C., Dillon, D. **Characterisation of a Vitrocell® VC 10 *in vitro* smoke exposure system using dose tools and biological analysis.** Chemistry Central Journal 2013, 7:146
- Kilford, J., Thorne, D., Payne, R., Dalrymple, A., Clements, J., Meredith, C., Dillon, D. **A method for assessment of the genotoxicity of mainstream cigarette-smoke by use of the bacterial reverse-mutation assay and an aerosol-based exposure system.** Mutation Research 2014, 769; 20-28
- Thorne, D., Kilford, J., Payne, R., Haswell, L., Dalrymple, A., Meredith, C., Dillon, D. **Development of a BALB/c 3T3 neutral red uptake cytotoxicity test using a mainstream cigarette smoke exposure system.** BMC Research Notes 2014; 7:367
- Breheny, D., Cunningham, F., Kilford, J., Payne, R., Dillon, D., Meredith, C. **Application of a modified gaseous exposure system to the *in vitro* toxicological assessment of tobacco smoke toxicants.** Environmental and Molecular Mutagenesis 2014; In Press
- Adamson, J., Thorne, D., Errington, G., Fields, W., Li, X., Payne, R., Krebs, T., Dalrymple, A., Fowler, K., Dillon, D., Xie, F., Meredith, C. **An inter-machine comparison of tobacco smoke particle deposition *in vitro* from six independent smoke exposure systems.** Toxicology In Vitro 2014, 28; 1320-1328

GR&D Centre
Regents Park Road
Millbrook
Southampton SO15 8TL
United Kingdom
Tel +44 (0)2380 58 8088

www.bat.com

www.bat-science.com

The Americas +1.888.COVANCE (+1.888.268.2623)
+1.609.419.2240
Europe/Africa +800.2682.2682 +44.1423.500888
Asia Pacific +800.6568.3000 +65.6.5677333
Web Site: www.covance.com

© COPYRIGHT 2014, COVANCE INC.



COVANCE

The assessment of the mutagenic potential of 3R4F mainstream cigarette smoke using multiple Ames strains

David Thorne¹; **Joanne Kilford**²; **Michael Hollings**²; **Annette Dalrymple**¹; **Mark Ballantyne**²; **Clive Meredith**¹; **Debbie Dillon**¹

Affiliations: ¹ Group R&D, British American Tobacco, Southampton, UK
² Covance Laboratories Ltd, Harrogate, North Yorkshire, UK

Corresponding author: David_Thorne@BAT.com

ABSTRACT

The Ames methodology is governed by clear international regulatory guidelines (e.g OECD 471), which recommend the use of at least five bacterial strains in an *in vitro* test battery. *Salmonella typhimurium* strains TA1535; TA1537 or TA97 or TA97a; TA98 and TA100 between them detect frameshift and base-pair substitutions. Either strain TA102 or an *Escherichia coli* (*E. coli*) strain (WP2 *uvrA* or WP2 *uvrA* (pKM101)) are accepted as a fifth strain and between them detect certain hydrazines, oxidising mutagens and cross-linking agents.

In this study we have modified the Ames assay, using a spread plate methodology, to allow exposure to cigarette smoke at the air-agar interface, which facilitates the assessment of the complete cigarette smoke aerosol. In total, nine *S. typhimurium* strains and one *E. coli* strain were investigated using varying dilutions of cigarette smoke (12.0, 8.0, 4.0 and 1.0 L/min), generated from a VC 10 Smoking Robot. Of the assessed strains, five tested positive (TA98, TA100, YG1024, YG1042 and TA104), four were negative (TA102, WP2 *uvrA* pKM101, TA97 and TA1535) and one strain (TA1537) was deemed incompatible with this scaled-down methodology and was not assessed with cigarette smoke due to the availability of an accepted alternative strain (TA97). A response was considered positive if greater than a two-fold increase over background spontaneous revertants was observed, combined with statistical differences ($p < 0.01$). In the case of a negative response, smoke exposures were increased from 24 to 64 minutes to further assess mutagenic activity. Finally, to support *in vitro* exposure and to quantify dose, deposited particulate mass ($\mu\text{g}/\text{cm}^2$) was assessed using Quartz Crystal Microbalance technology *in situ* of exposure.

In conclusion, we have assessed an OECD acceptable battery and additional Ames strains for their responsiveness to mainstream cigarette smoke. Based on these data, we propose a selection of these strains could be appropriate to assess the genotoxicity of current and future aerosol-based tobacco products.

Abstract ID:- #344
Poster Number:- STPOST 20

CORESTA Congress Meeting 2014
12-16th October
Quebec City
Quebec
Canada



COVANCE