

E-cigarette Aerosol Dynamics in a Physical Model of the Adult Human Oral/Pharyngeal Cavity

WANG Q. ¹; LI W. ²; CASTRO N. ²; ZHANG J. ²;
PITHAWALLA Y. ²; OLDHAM M. ²; LIPOWICZ P. ²; and
ROSTAMI A. ²

¹ Lancaster Laboratories, c/o Altria Client Services LLC, Center for Research & Technology, 601 E. Jackson Street, Richmond, VA 23219

² Altria Client Services LLC, Center for Research & Technology, 601 E. Jackson Street, Richmond, VA 23219



Altria

Altria Client Services

Objective

- ❑ To generate experimental data to validate a computational fluid dynamic (CFD) model for e-cigarette aerosol deposition in respiratory tract



Physical Model

- Physical Prototypes created from digital geometry using 3D printer
- Wall covered with a layer of cotton cloth that can be saturated with water to reflect high relative humidity in respiratory tract

Oral/Larynx/Pharynx section

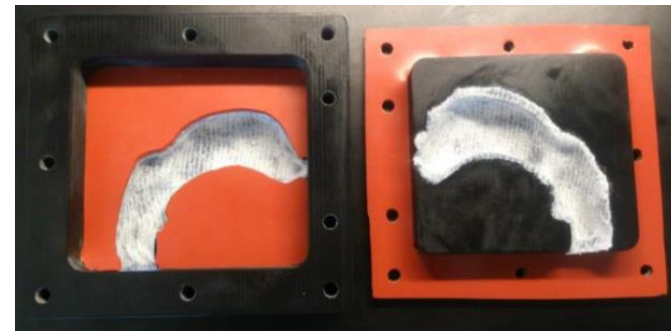
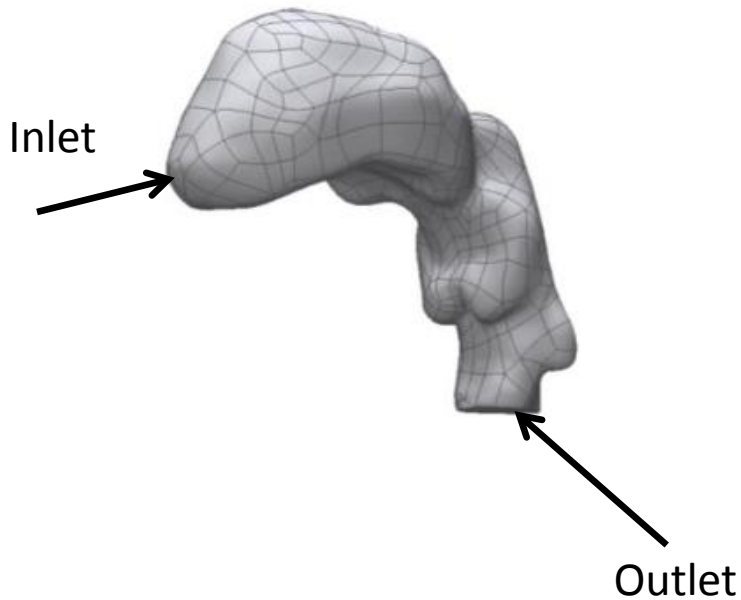

Physical Model Assembly

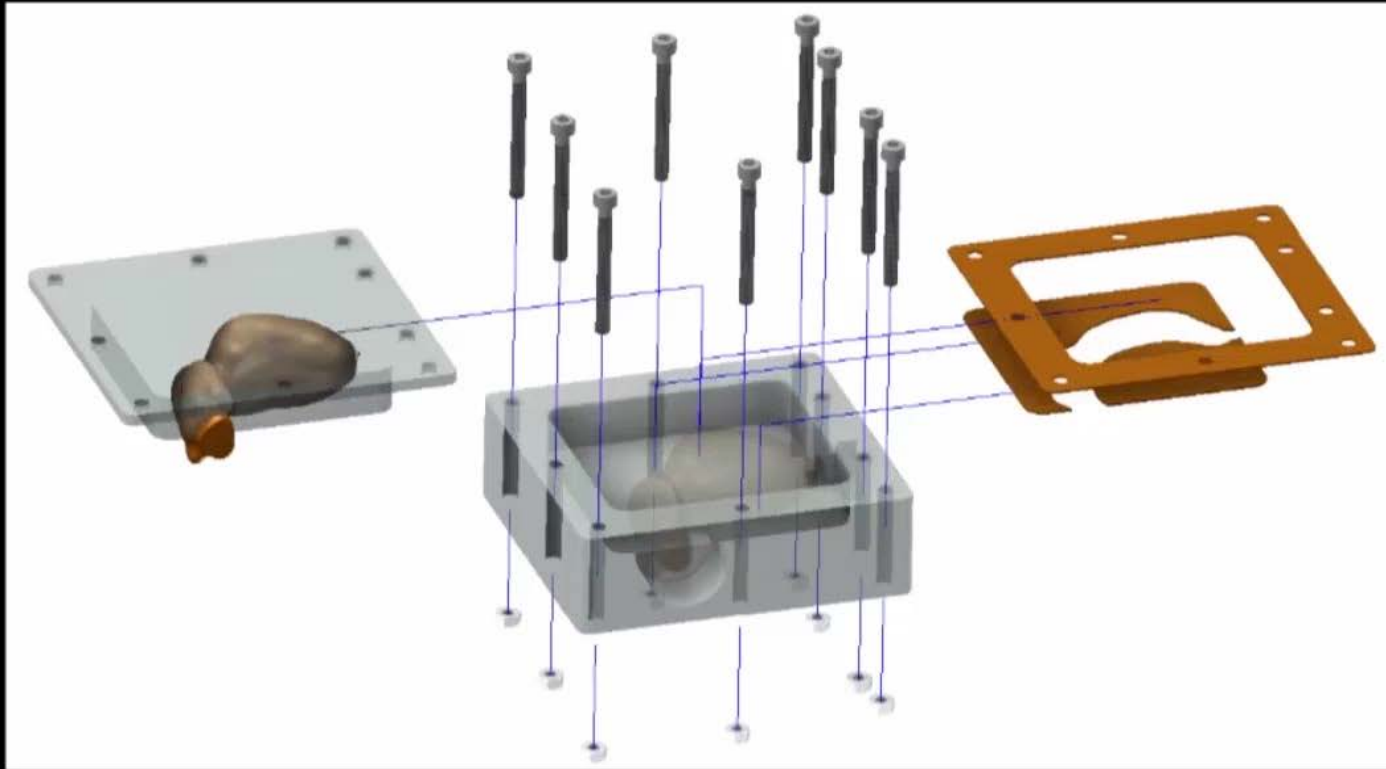
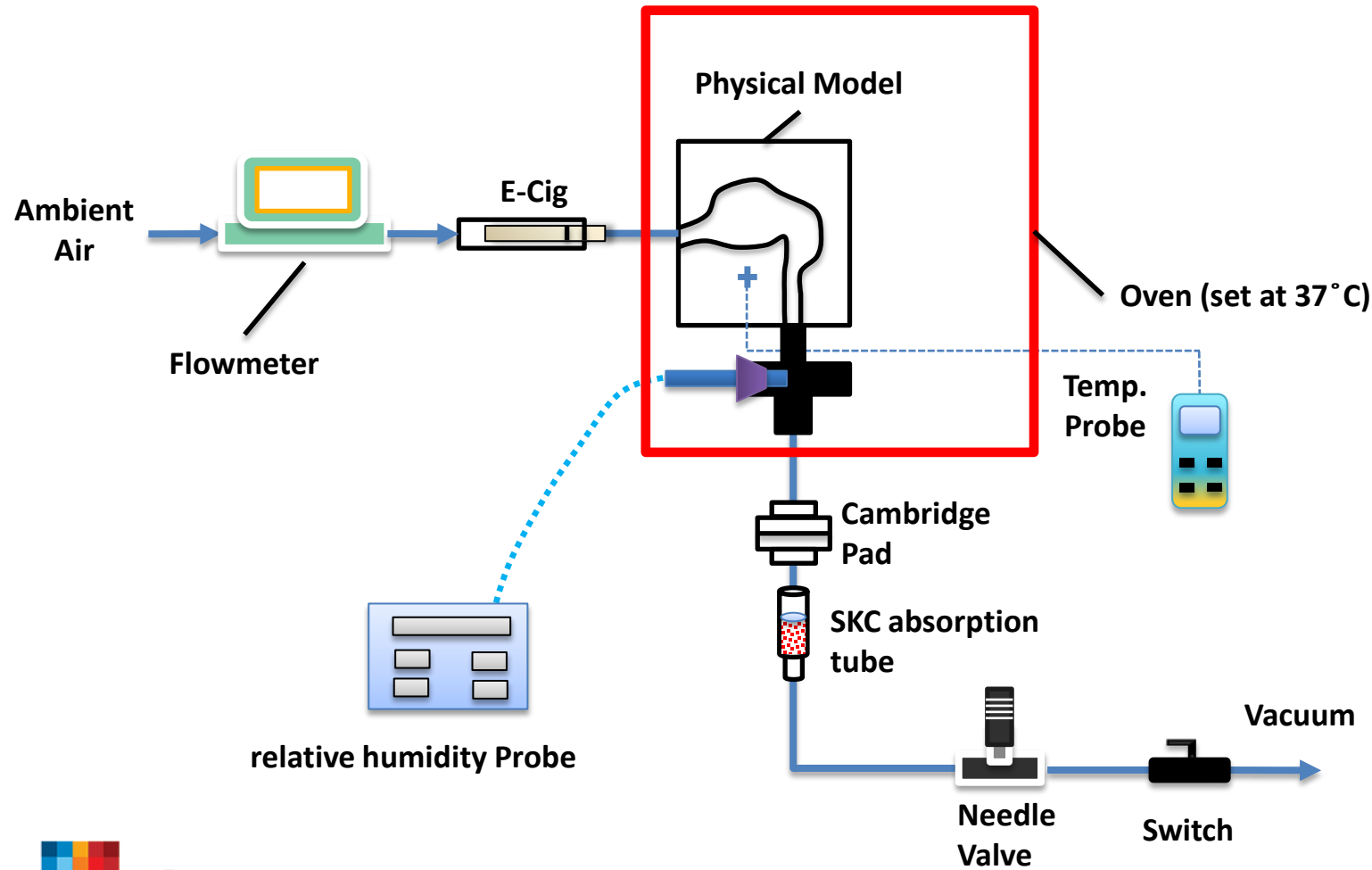

Diagram of the Experimental Setup



Experimental Conditions

Case	E-liquid composition	puff duration (sec.)	puff volume (cc)	Temperature (C)	Wall conditions
N-1	2.5% Nicotine by weight (NBW), 15% water, 49.5% PG/Gly 33%	3	55	37	wet
N-2	2.5% NBW, 15% water, 49.5% PG/Gly 33%	3	55	37	dry
N-3	100% Propylene Glycol (PG)	3	55	37	wet
N-4	100% Glycerin (Gly)	3	55	37	wet

- 3 puffs E-cig warm up
- 1.1 L/min constant flow rate
- 11 sec air wash between puffs
- 3 replicates /cartridge and 3 cartridges/case
- 5 puffs for gravimetric analysis
- single puff for chemical analysis using GC/MS
- Doesn't represent real inhalation
- Single fixed geometry
- Simple formulations without flavors

Gravimetric Analysis

Results – Gravimetric Analysis

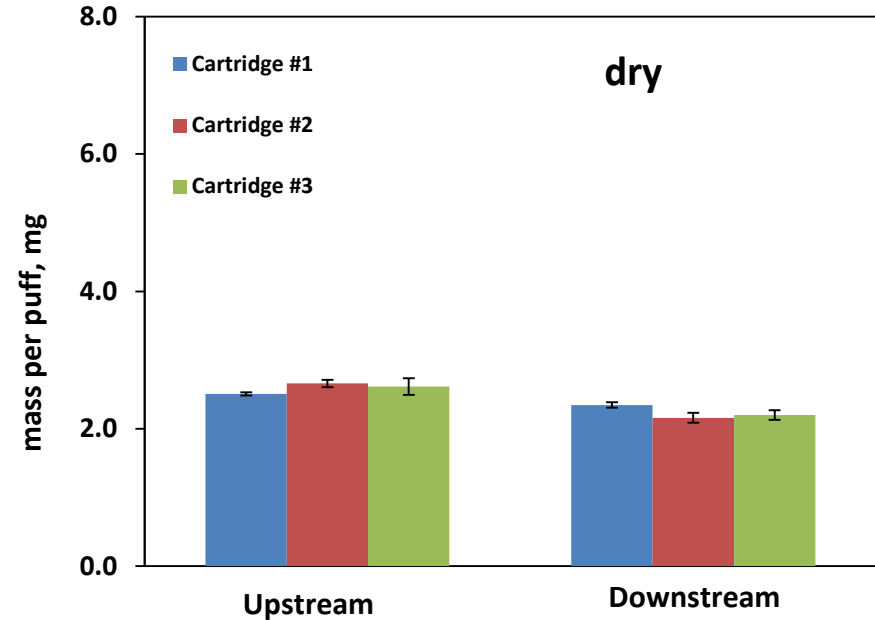
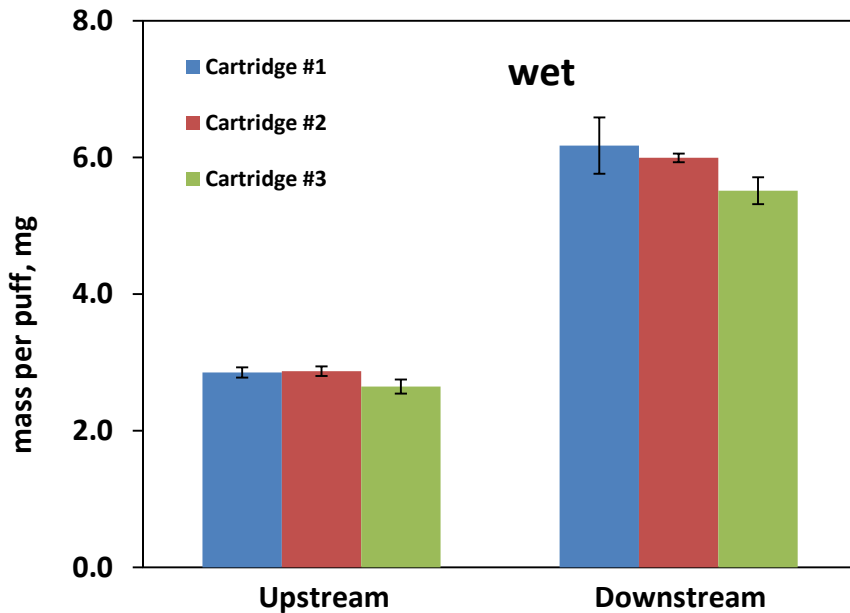

2.5% NBW, 15% water, 49.5% PG/Gly 33%

Results – Gravimetric Analysis

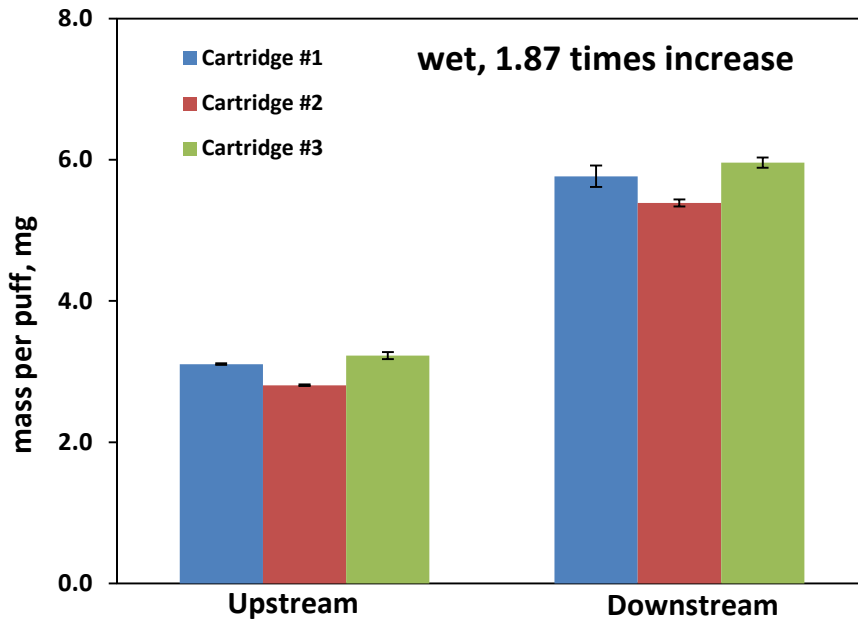

100% PG

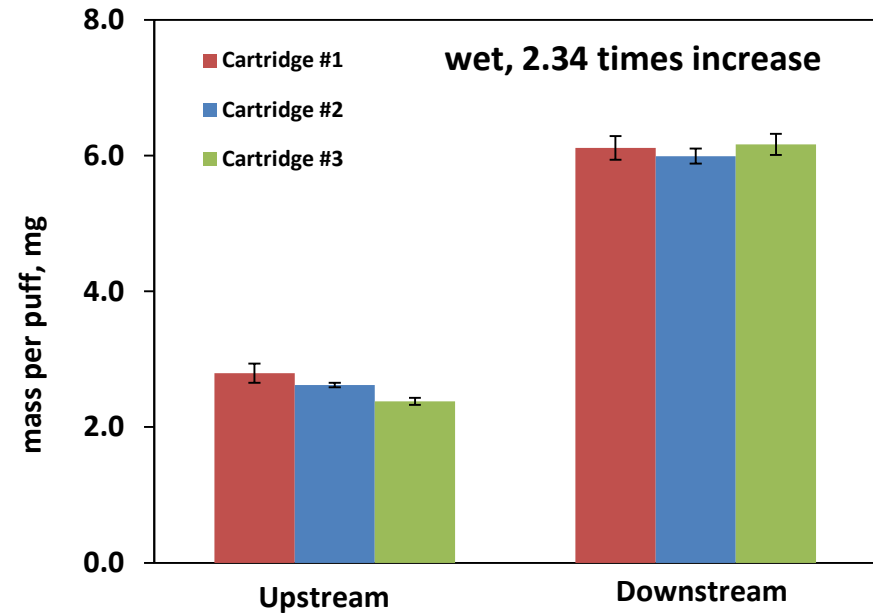

100% Gly

Chemical Analysis



Altria
Altria Client Services

Results – Chemical Analysis (wet)

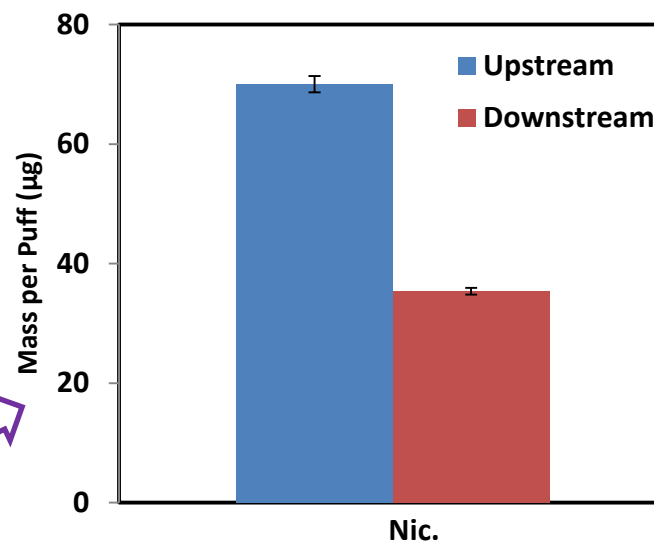
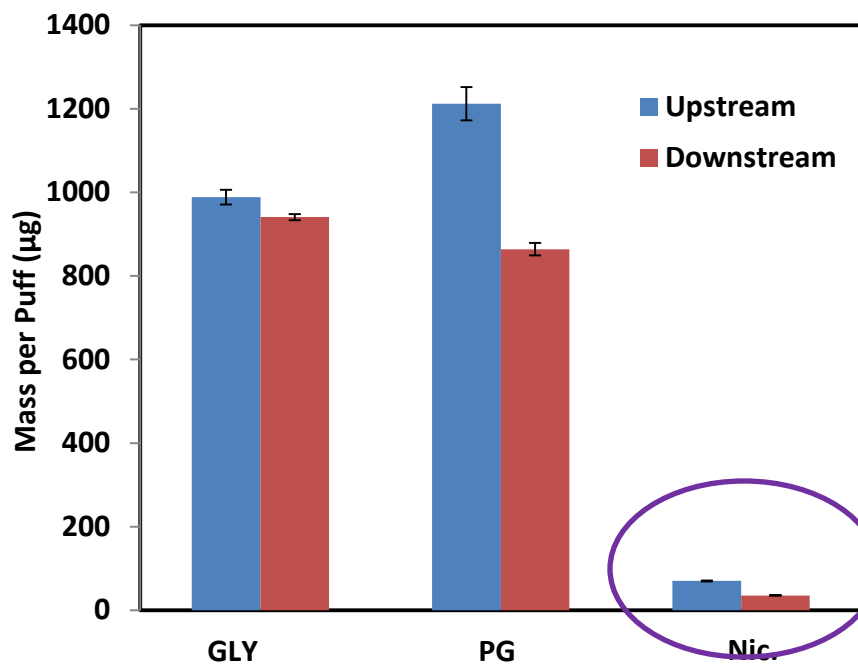

2.5% NBW, 15% water, 49.5% PG/Gly 33%

Results – Chemical Analysis (dry)

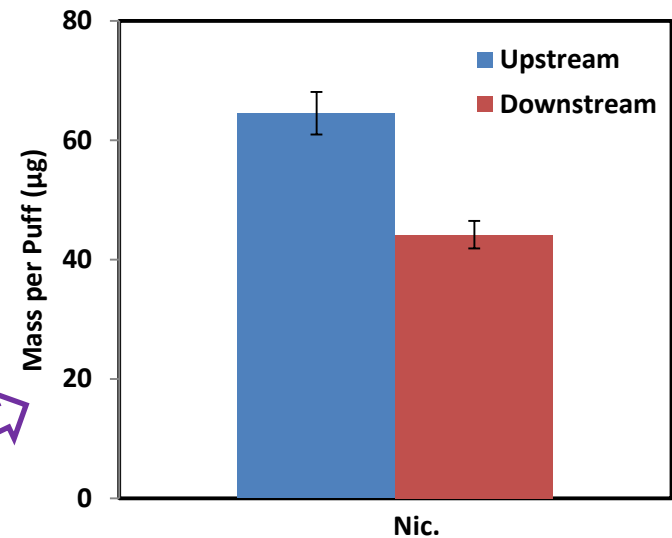
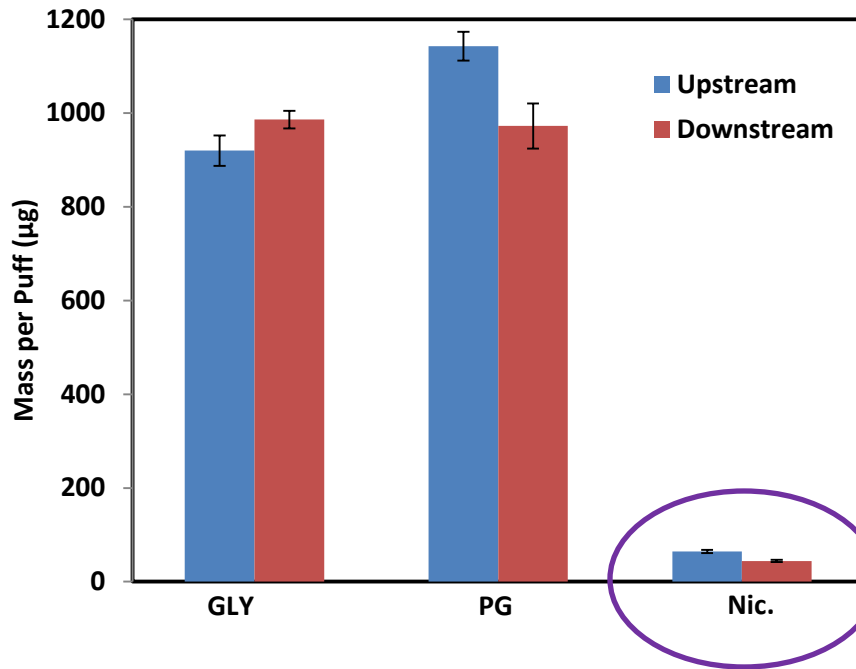

2.5% NBW, 15% water, 49.5% PG/Gly 33%

Results – Chemical Analysis (wet)

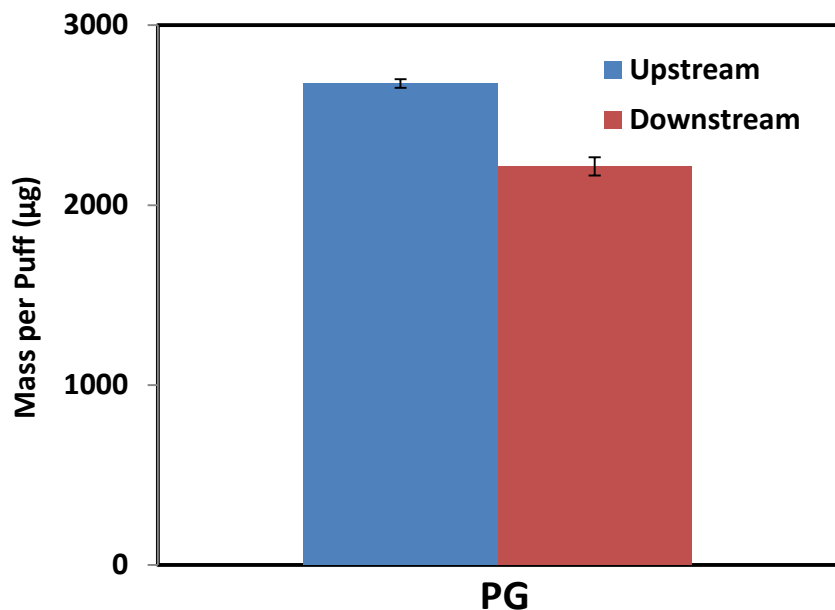

100% PG

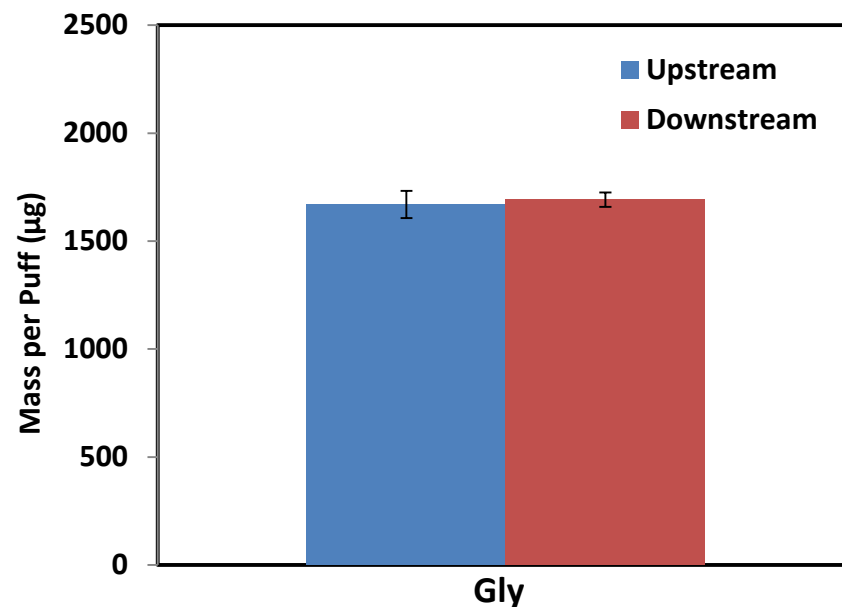

100% Gly

Summary

- A physical model mimicking the human respiratory tract was developed.
- High relative humidity resulted in hygroscopic growth of particles, which depended on the composition of e-cig aerosols.
- The loss of PG and Nicotine is higher than the loss of Glycerin.

Thank You!



Altria
Altria Client Services