

Characterization of the Vitrocell® High Throughput Exposure Module Using Different Tobacco Product Types

¹Leverette R, ¹Keyser B, ²Seymour A, ²Hollings M, and ¹Bombick B

¹Scientific & Regulatory Affairs, RAI Services Company, Winston-Salem, NC 27102

²Covance Laboratories Ltd, Harrogate, North Yorkshire HG3 1PY, UK



Abstract

The development of whole smoke / aerosol exposure systems provides a means to conduct *in vitro* assessment of freshly generated whole smoke and aerosol from combustible and tobacco heating products (THP) as well as electronic nicotine delivery systems (ENDS). One challenge with such systems is ensuring sufficient throughput for *in vitro* toxicological studies in a timely manner. Vitrocell® has developed a high throughput whole smoke / aerosol exposure module designed to deliver concurrently up to seven different doses of smoke / aerosol and a clean air control to 48 wells of bacterial or mammalian cell cultures (six wells per dose). Characterization of this system was conducted with a series of experiments designed to assess smoke / aerosol delivery and biological responses from a Kentucky Reference 3R4F combustible cigarette or a commercially available THP. Dilution airflows consisting of 0.5 – 10 L / min for 3R4F and 0 (undiluted) - 4 L / min for the THP were evaluated. Smoke / aerosol deposition was quantified using fluorescence measurements (Ex 355 / Em 485) of captured particulate matter and chemical analysis (e.g., glycerol, nicotine) of either DMSO (3R4F) or PBS (THP) traps within the module. Further characterization of the high throughput module was performed with the Neutral Red Uptake (NRU) assay to determine the cytotoxic response to 3R4F whole smoke. Current results demonstrate a dose-dependent deposition of smoke / aerosol constituents and a characteristic dose-dependent decrease in cell viability as indicated by the NRU assay.

Materials and Methods



Figure 1: Vitrocell® high throughput exposure module.

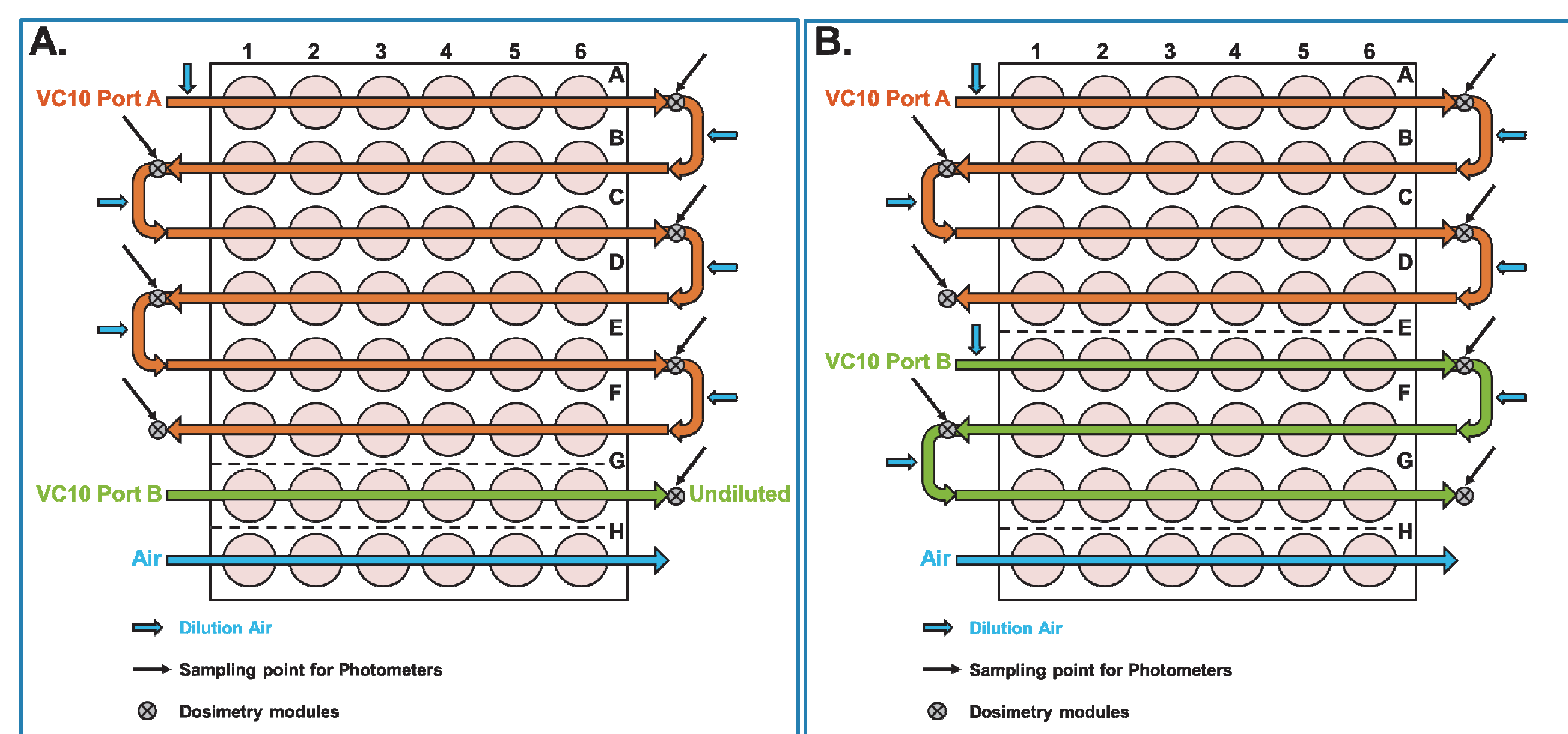
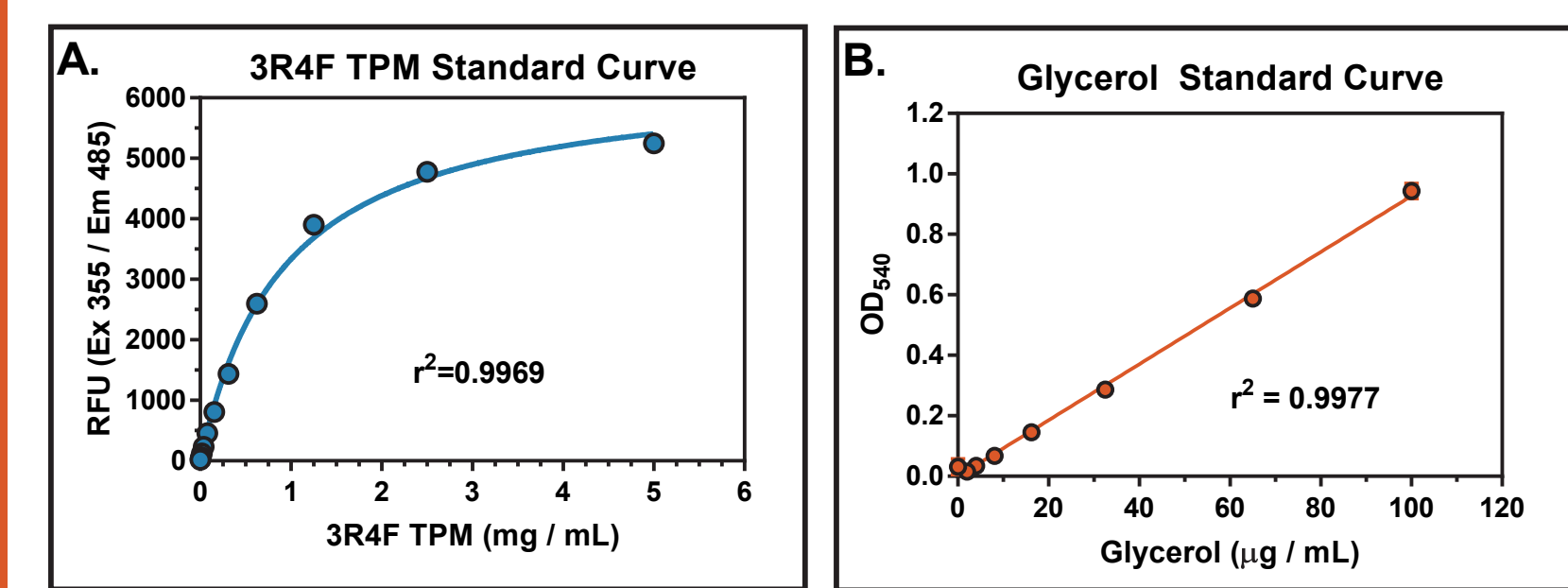

Figure 2: Vitrocell® high throughput exposure module set-up for either the THP (A) or the 3R4F combustible cigarette (B). Diagrams indicate placement of photometers (—), dosimetry modules (⊗) and addition of air for smoke / aerosol dilution (⇒).

Results

Figure 3: 3R4F Total Particulate Matter (TPM) (A) and Glycerol (B) standard curves.



Pad-collected 3R4F TPM (in DMSO) was serially diluted and fluorescence (Ex 355 / Em 485) was measured over a range of concentrations. Hyperbola model was used to fit the curve and extrapolate 3R4F TPM deposition within the exposure module (GraphPad Prism). Known concentrations of glycerol (µg / mL) were quantified using Free Glycerol Reagent (Sigma # FG0100) with a linear model used to fit the curve and extrapolate THP delivery within the exposure module.

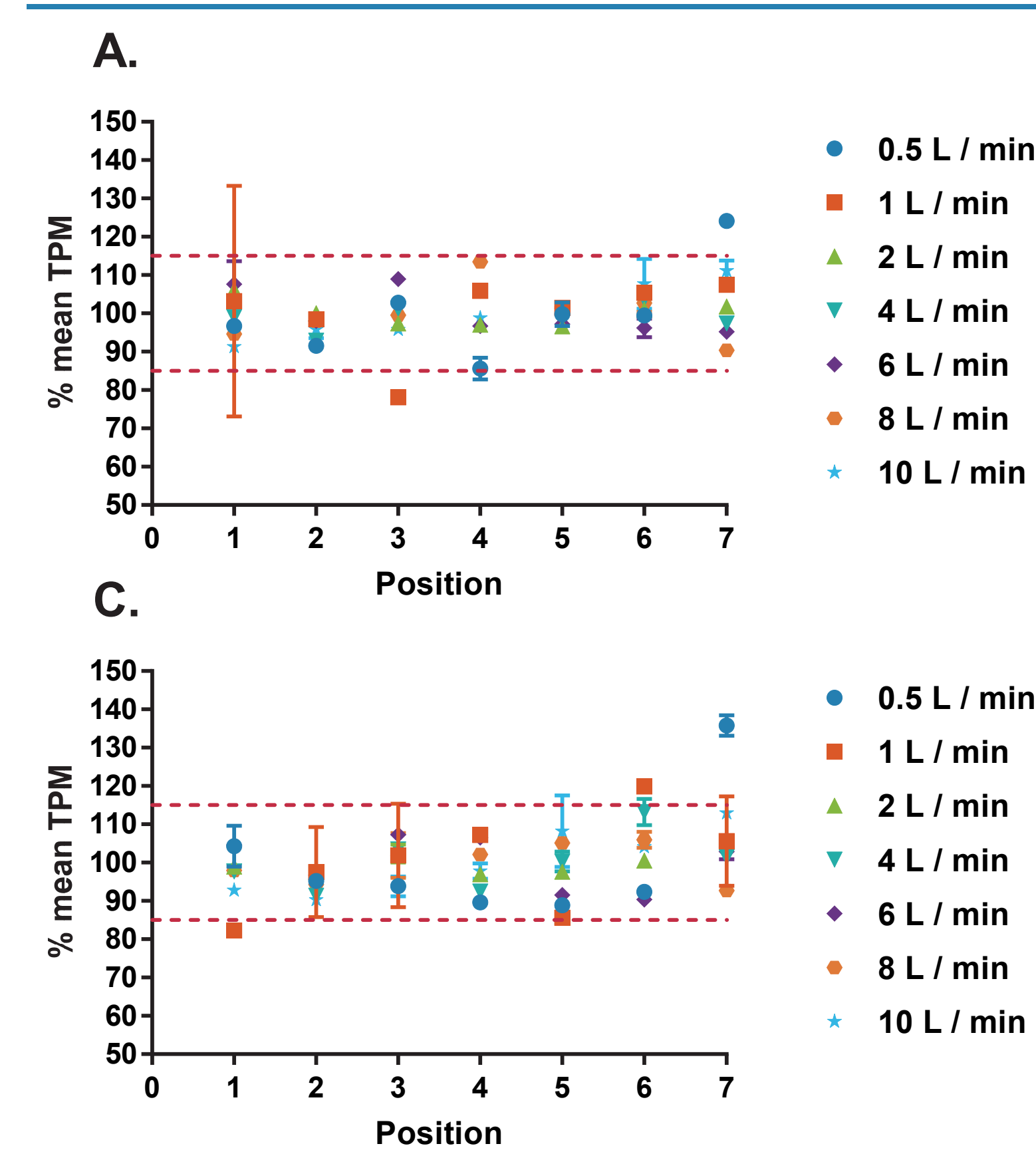

Figure 4: 3R4F TPM deposition in high throughput module.

Deposition of 3R4F TPM for each dose (dilution air; L / min) at each position (position #7 = dosimetry module) was determined by extrapolation of the Ex 355 / Em 485 fluorescence of smoke-exposed DMSO to the standard curve (Figure 3A). Values are presented as % of the overall mean for each dose. Dashed lines (--) are at ± 15%. Graphs A, B and C represent three independent exposures.

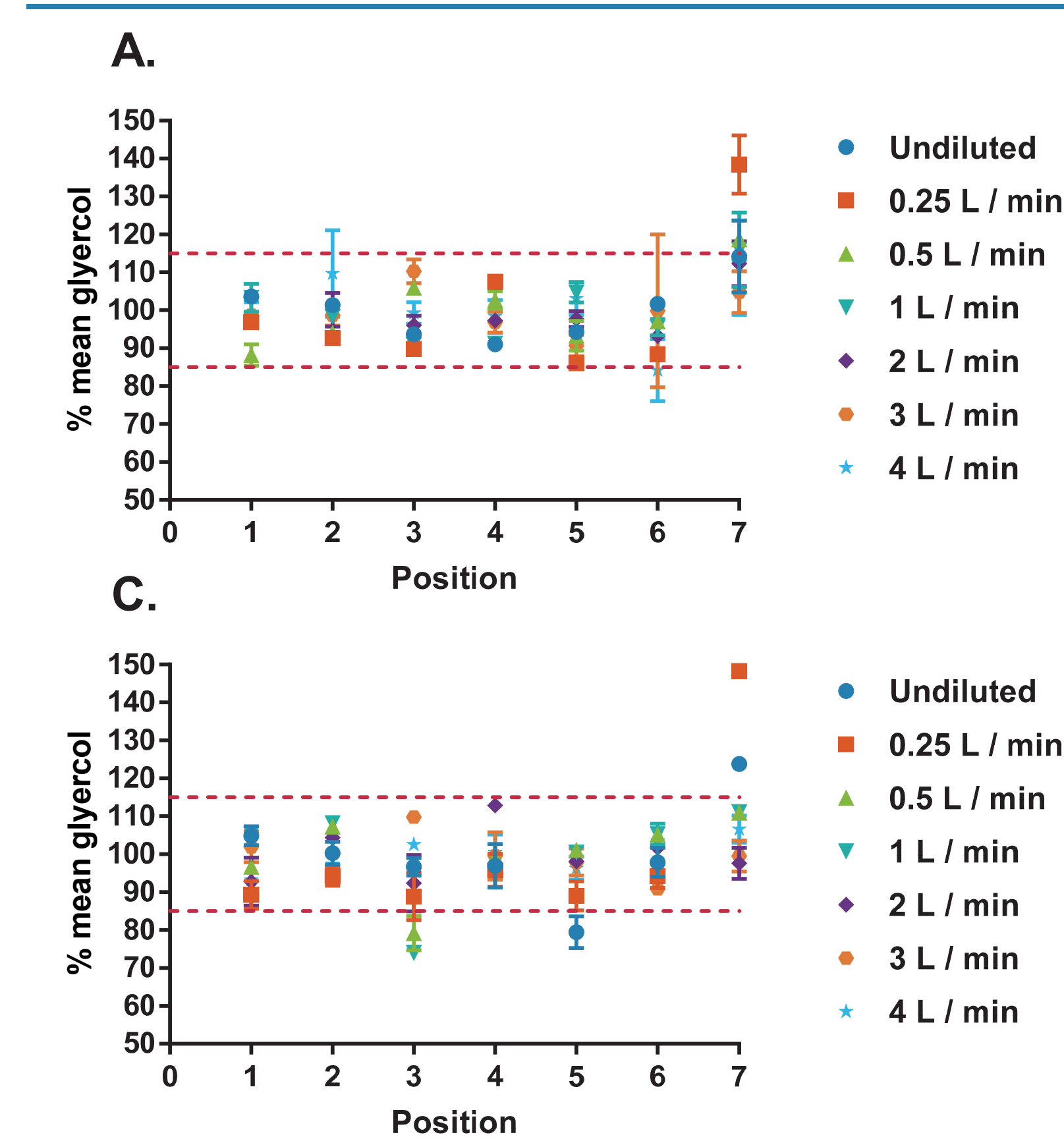
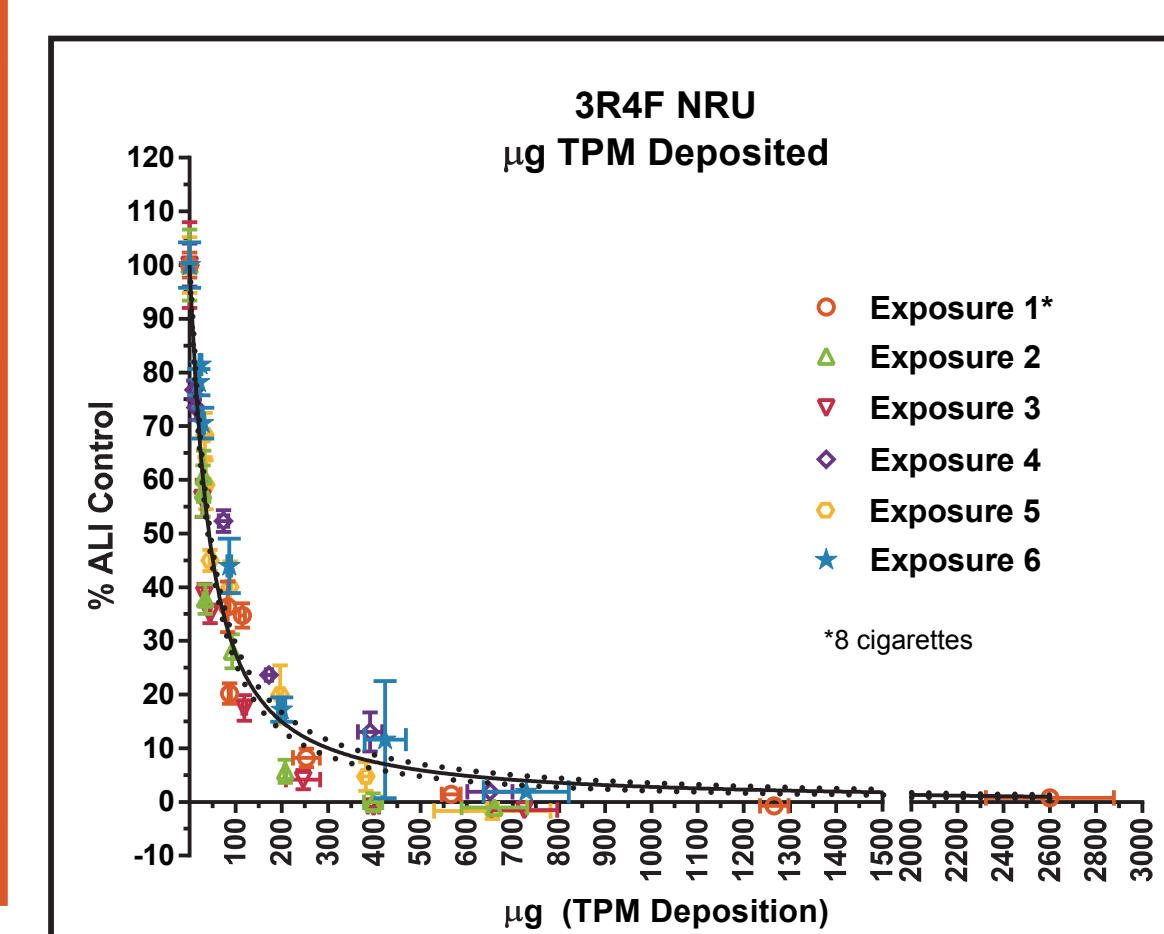

Figure 5: THP glycerol deposition in high throughput module.

Deposition of glycerol for each dose (dilution air; L / min) at each position (position #7 = dosimetry module) was determined by extrapolation of OD₅₄₀ of aerosol-exposed PBS to the standard curve (Figure 3B). Values are presented as % of the overall mean for each dose. Dashed lines (--) are at ± 15%. Graphs A, B and C represent three independent exposures.



Exposure	r ²	IC ₅₀	SE
1*	0.9633	47.3	6.6
2	0.9563	34.4	1.8
3	0.9756	28.4	1.3
4	0.9728	50.1	3.2
5	0.9612	51.1	2.5
6	0.9787	65.1	2.9
Global Fit	0.9388	42.4	1.3

Figure 6: 3R4F Whole Smoke Cytotoxicity (NRU). CHO-WBL cells were exposed to whole smoke generated from 3 x 3R4F cigarettes, with the exception of Exposure 1 which was 8 x 3R4F cigarettes. TPM deposition (µg) was extrapolated from the 3R4F TPM standard curve (Figure 3A). IC₅₀ values (µg TPM ± SE) calculated using GraphPad Prism. Global Fit (curve presented on graph) is the best fit using all data points from the six independent exposures.

Materials and Methods

Smoke / Aerosol Delivery and Distribution:

- Prior to smoking, THP and 3R4F cigarettes were conditioned at least 48 hrs at 22 ± 1°C and 60 ± 3% relative humidity².
- Each well in the high throughput module and the dosimetry modules (one per row) contained a stainless steel insert with 3 mL of PBS (THP) or DMSO (3R4F).
- Dilution air flow rates (7 per exposure) were as follows:
 - THP: 0 (undiluted), 0.25, 0.5, 1.0, 2.0, 3.0 and 4 L / min
 - 3R4F: 0.5, 1.0, 2.0, 4.0, 6.0, 8.0 and 10 L / min
- Vacuum flow rate to exposure wells was 5 mL / min.
- 3R4F and THP were both puffed on a Vitrocell® VC10 under HCl regimen: 55 mL puff volume, 2 sec puff, 30 sec puff interval; 100% vent blocking for 3R4F only (no vent holes on THP).
- 3R4F: 11 puffs / cigarette, 8 cigarettes / exposure, 44 min exposure
- THP: 12 puffs / consumable, 10 consumables / exposure, 60 min exposure
- 8 sec puff exhaust to deliver smoke / aerosol to high throughput module

3R4F Dosimetry:

- Pad-collected TPM was extracted in DMSO to a concentration of 24 mg / mL, serially diluted and Ex 355 / Em 485 fluorescence was measured to generate standard curve (Figure 3A).
- Ex 355 / Em 485 measures were taken in triplicate from the smoke-exposed DMSO and standard curve was used to extrapolate TPM delivered to each well.

THP Dosimetry:

- THP delivered dose was correlated to glycerol captured in aerosol-exposed PBS, and quantified using Free Glycerol Reagent (Sigma # FG0100).

Neutral Red Uptake Assay (NRU):

- CHO-WBL cells, supplied by the European Collection of Cell Cultures, were seeded at 3 x 10⁵ cells per 24 mm Transwell in McCoy's 5A complete media (with serum), incubated at 37 ± 1°C for 18 - 24 hrs in a humidified atmosphere of 5% (v/v) CO₂ to achieve approximately half-confluent monolayers for exposures.
- For dosimetry, stainless steel inserts containing 3 mL DMSO were placed in position '3' and in the dosimetry modules for each row (Figure 2B).
- 3R4F cigarettes were smoked as above using the same dilution air flow rates.
- After exposure at the air-liquid-interface (ALI), cells were incubated at 37 ± 1°C in a humidified atmosphere of 5% (v/v) CO₂ in air for ~24 hrs. Neutral Red solution (50 µg / mL) was added and incubated for 3 hrs, followed by washing and destaining.
- Absorbance of extracted Neutral Red (OD₅₄₀) from exposed cells was compared to air exposed control and expressed as % ALI Control (Figure 6). IC₅₀ values (µg TPM ± SE) were calculated using GraphPad Prism.

Conclusions

- Within independent exposures, aerosol from a commercial THP and whole smoke from the 3R4F reference cigarette were consistently delivered across each row (dose) and corresponding dosimetry module, falling within 15% of the mean TPM or glycerol deposited.
- Overall coefficients of variation (CV) for both aerosol and smoke deposition within a dose were typically < 15%, with few exceptions where THP and 3R4F exposures had CV's ranging from 15 - 22%.
- Cytotoxicity of 3R4F whole smoke, as determined by the NRU assay, was fairly consistent (n = 6), with IC₅₀ values ranging from 28.4 - 65.1 µg TPM (mean IC₅₀ = 46.1 ± 12.0; 25% CV).

References:

1. Aufferdeide, M and Gressmann, H. (2007) A modified Ames assay reveals the mutagenicity of native cigarette mainstream smoke and its gas vapour phase. *Experimental and Toxicologic Pathology*, 58, 383 - 392.
2. ISO 3402 (1999). Tobacco and tobacco products - Atmosphere for conditioning and testing (4th edition)